

The information disclosed herein is the property of the originator who reserves all patent, design, proprietary, manufacturing, use and sales rights thereto, except for the rights expressly granted to others. This document shall not be reproduced nor shall the information contained within be used by or disclosed to others except as expressly authorized by the originator.

| Revision Letter | Change Description | 12/07/16 |
|-----------------|--|----------|
| A | Detail B: AN3-15A Bolts, 4 Required was AN3-20A Bolts. | |
| B | Detail B: AN3-14A Bolts, 4 Required was AN3-15A Bolts. Part Change: SNB-G01-11 Fuel Tank Straps replaced SNB-G01-10 Straps. Installation Instructions Added: Added "Preparing and Installing the Fuel Tank" Instructions. -02 Tank Installation: Added Hardware call-outs for new Fuel Tank Strap halves. | 6/22/21 |
| C | "Preparing and Installing the Fuel Tank": Revised procedure to season the tank in the airframe rather than out of the airframe. | 9/09/21 |

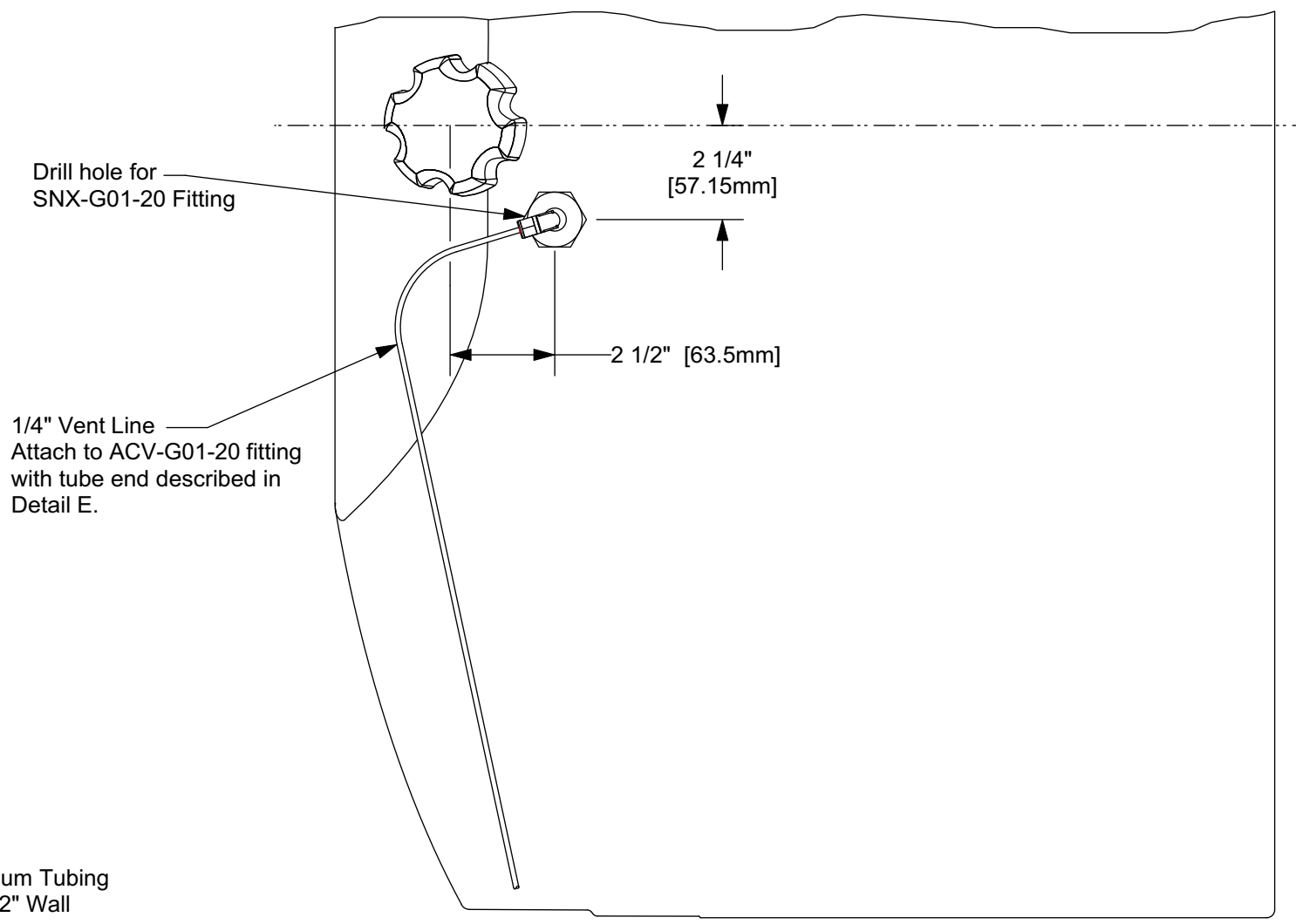

Detail D
-6 AN Tube End Detail
Scale: None

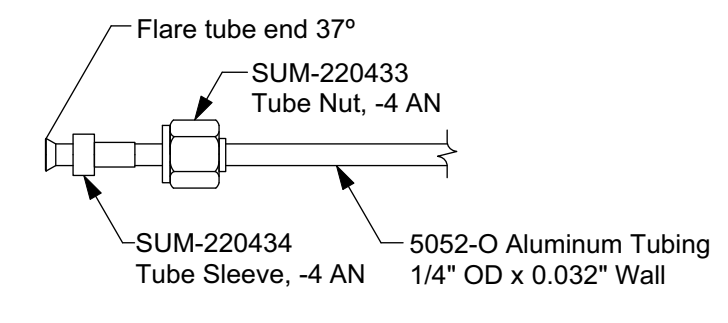

Detail E
-4 AN Tube End Detail
Scale: None

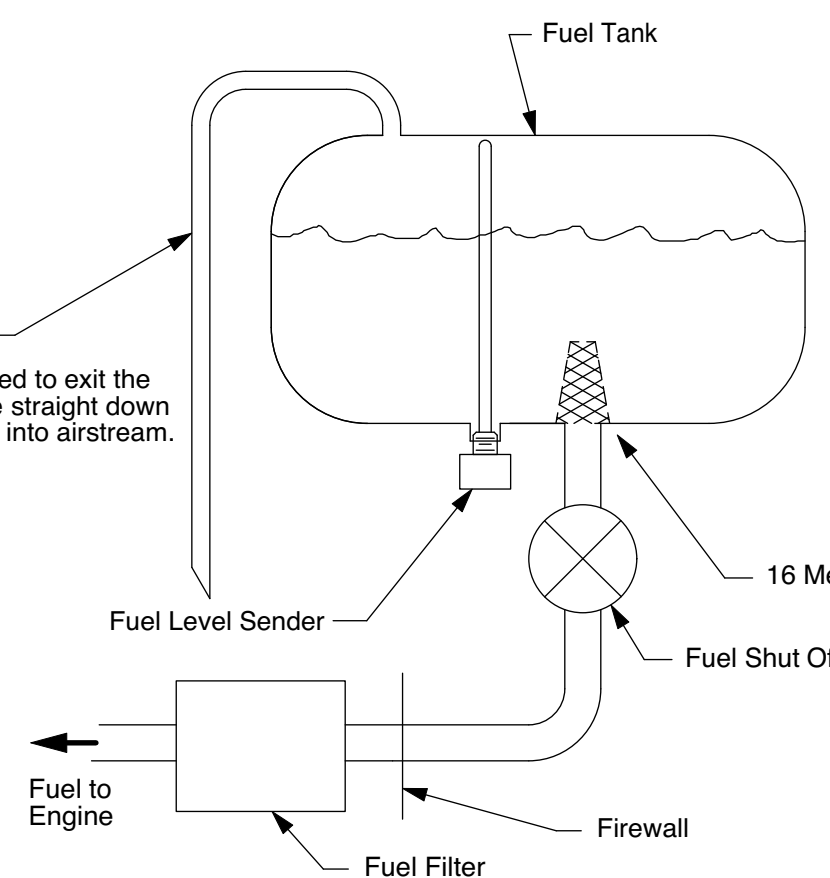

Fuel System Schematic
Scale: None

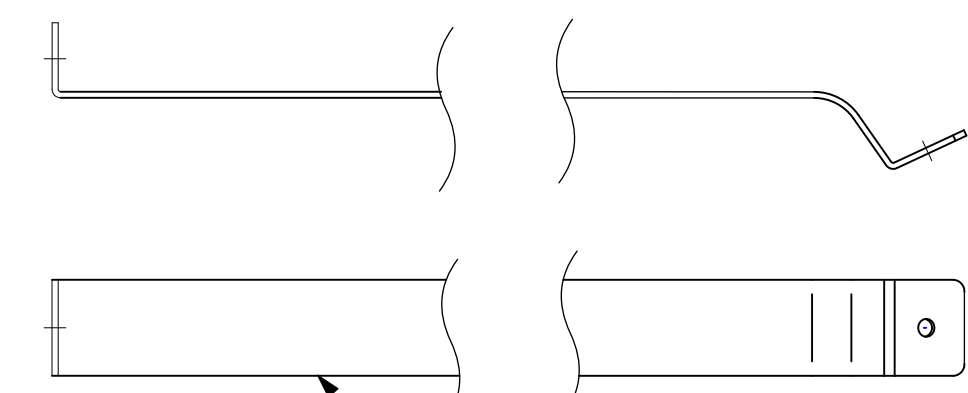

SNB-G01-11
Tank Strap, 4 Required

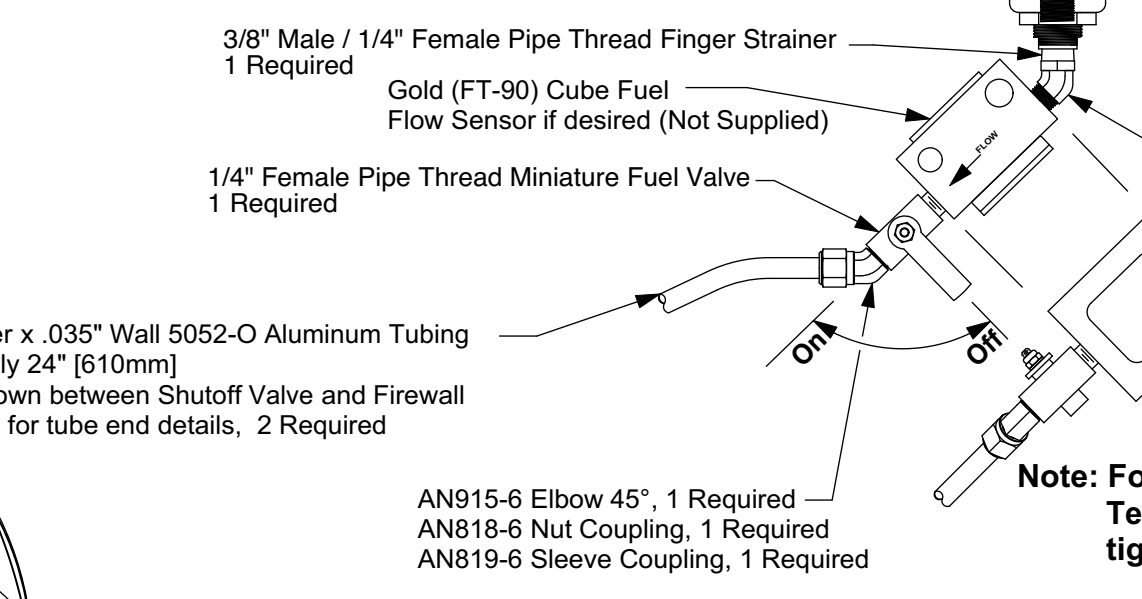
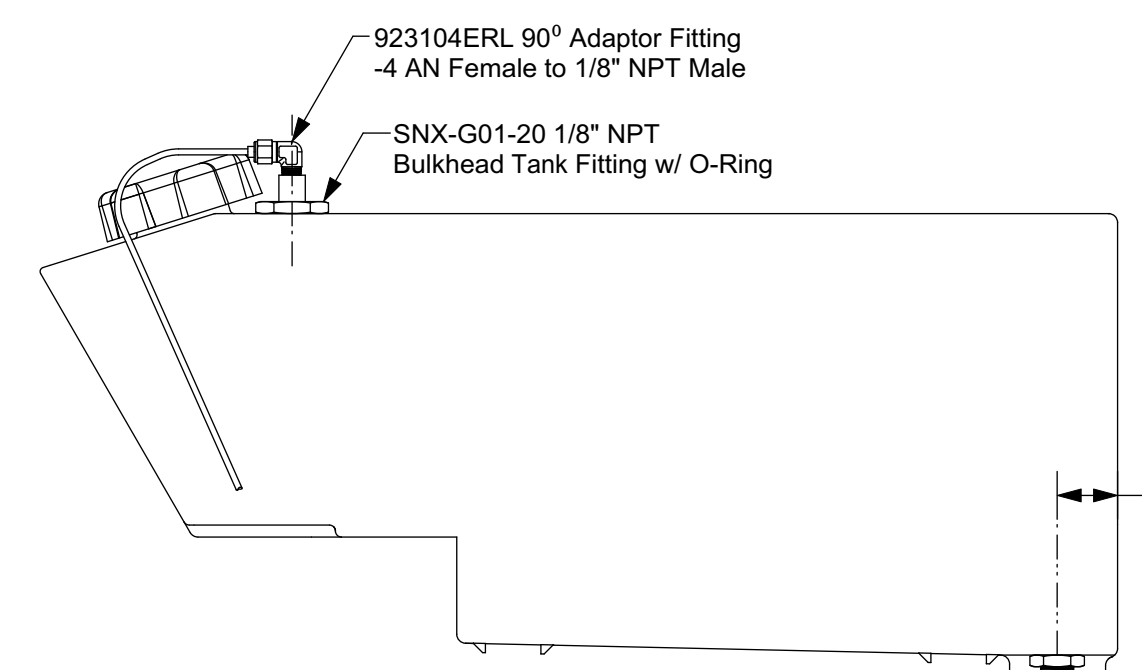

Note: For all NPT fittings apply Teflon paste before tightening lines.

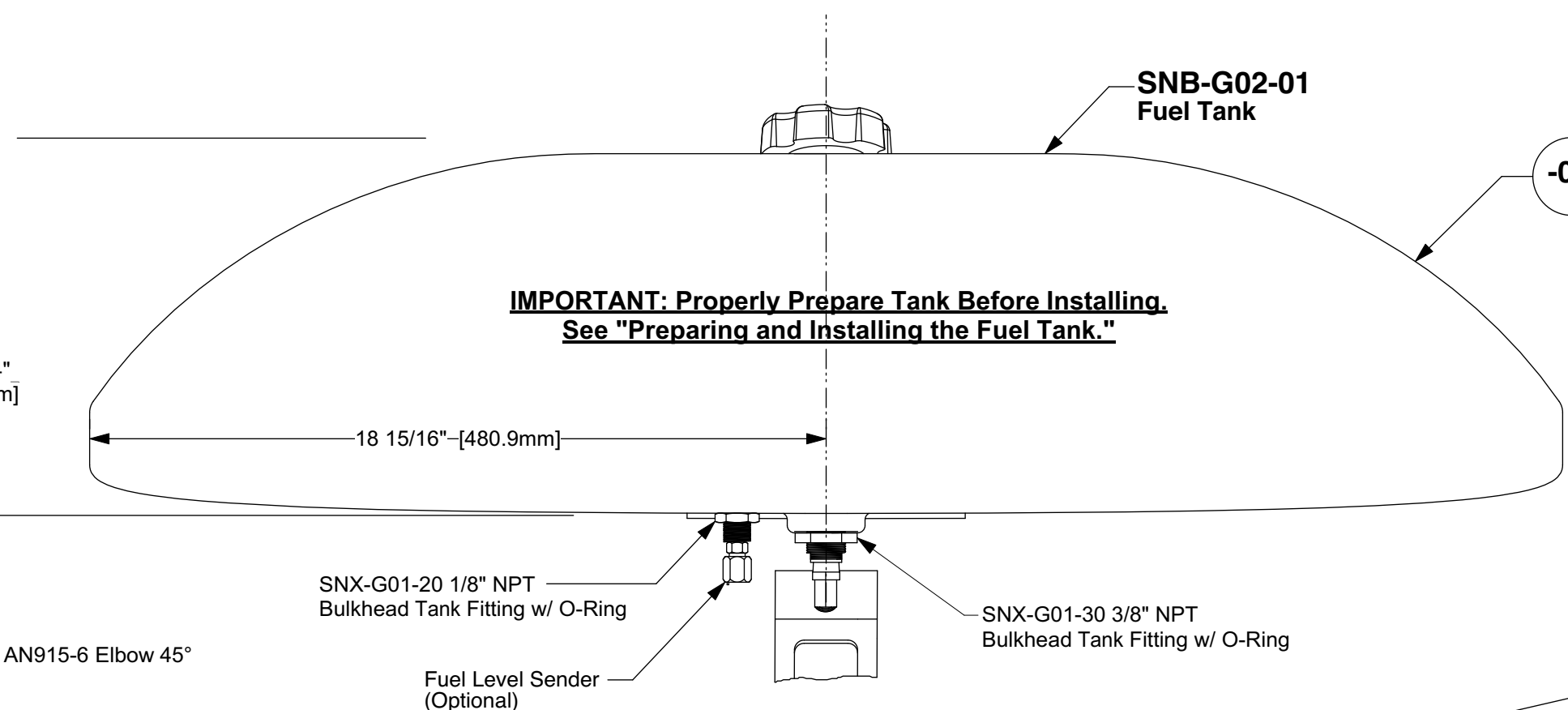

-05 Tank Assembly
Scale: 1/4

! IMPORTANT !
Preparing and Installing the Fuel Tank:

The fuel tank expands when exposed to fuel. To prevent distortion of the tank this procedure must be followed. Failure to follow this procedure may result in a distorted, unairworthy fuel tank installation.

Danger! Fuel and fuel vapors are explosive. Avoid serious injury or death. Keep fuel and filled fuel tank away from all ignition sources including heaters, electrical equipment, open flames, sparks, etc. **DO NOT drill into the tank after fuel has been introduced.**

1. Install the Bulkhead fittings in the fuel tank.
2. Thoroughly clean the inside of the fuel tank with water.
3. Let the tank dry.
4. Plug the bulkhead fittings with pipe plugs.
5. Attach the fuel tank straps to the upper longerons. See Detail B.
6. Install the fuel tank, leaving the support straps loose but joined.
7. If the glare shield and instrument panel are not already installed, install them with clecos.
8. Add about 2 gallons of fuel to the tank.
9. Install the fuel cap.
10. Leave the fuel tank sealed for 6 weeks. During this time the tank will expand slightly.
11. After about 6 weeks, drain the fuel from the tank.
12. Tighten the bolts that hold the fuel tank strap halves together. Do not over-tighten the bolts. The straps should contact the tank in places but not put pressure on the tank.
13. Complete plumbing the fuel tank, mindful of the remaining, potentially explosive fuel vapors.

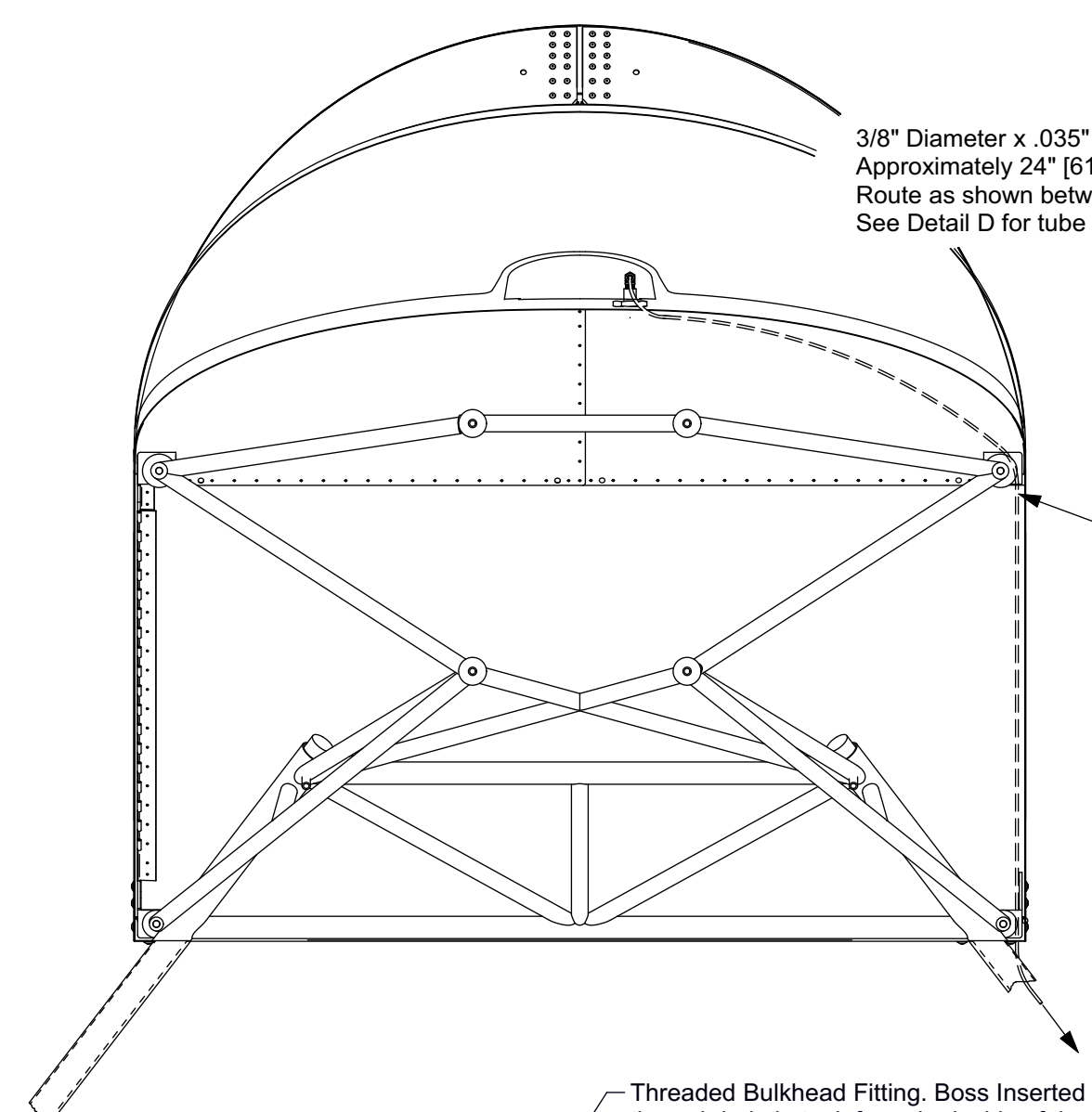

For Vent Line:
1/4" Diameter x .032" Wall 5052-O Aluminum Tubing
Approximately 70" [1610mm]
Route as desired, secure with plain clamps:
AN742-D4 Plain Clamp
AN526-832R8 Machine Screw
AN960-8 Washer
AN965-832A Nut
*number required depends on routing and builder preference. Four (4) sets included in hardware kit.

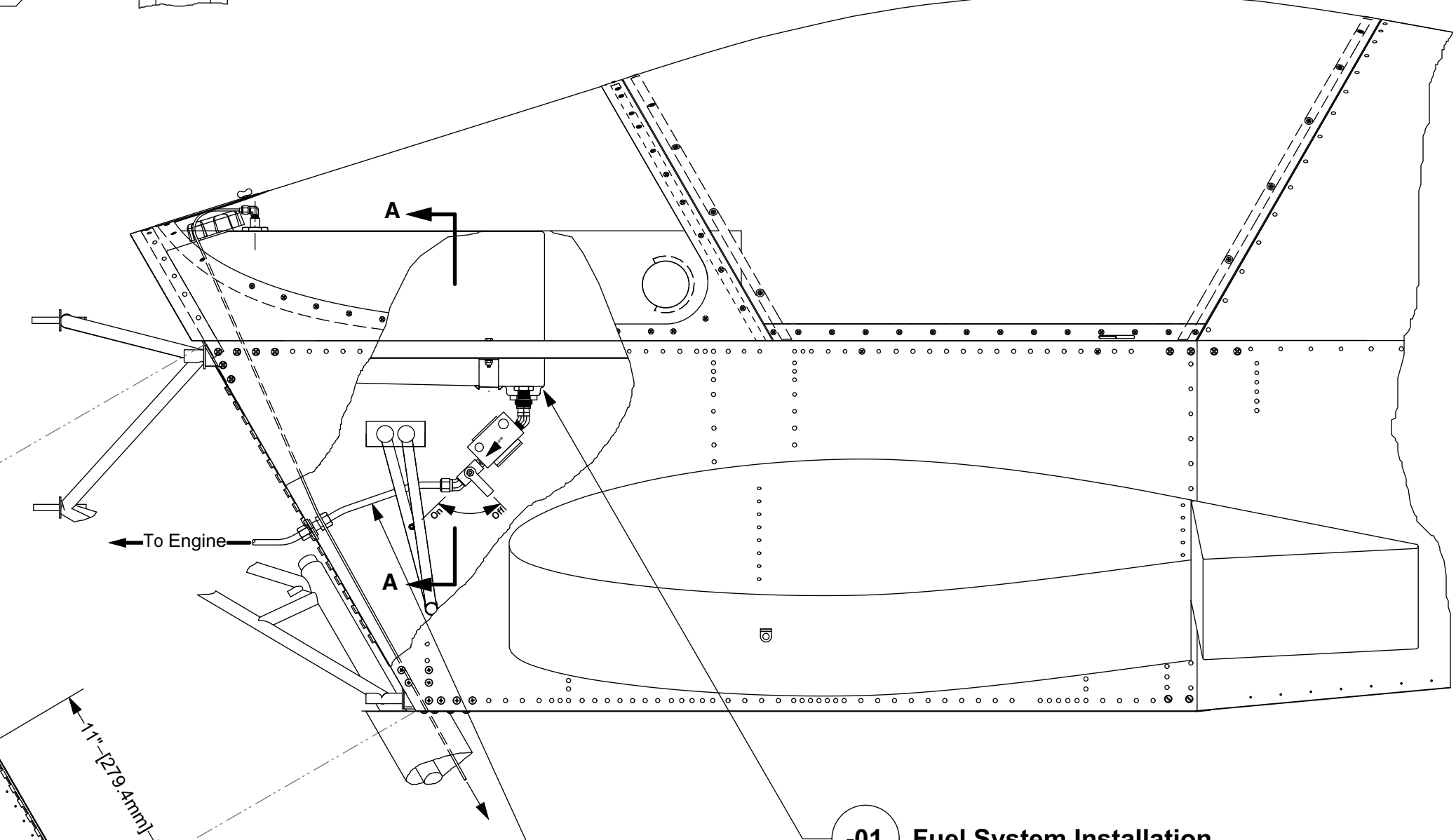

-01 Fuel System Installation

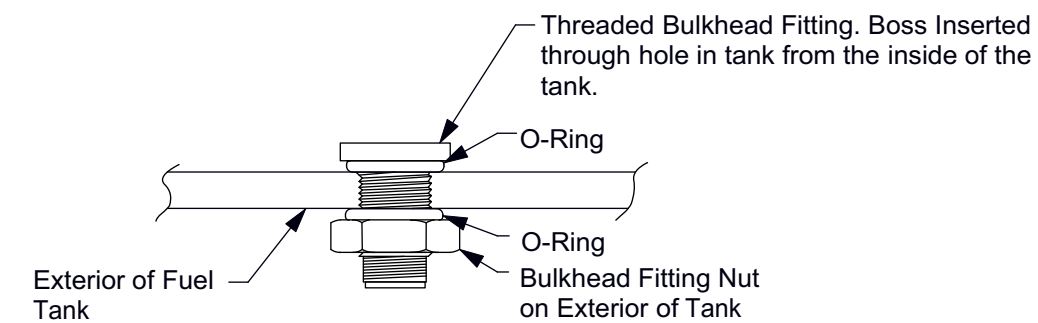

Detail C
Bulk Head Fitting Detail
Scale: 2:1
Typical for Both Sizes

- Installing Bulkhead Fitting:**
Note: This is just one method which can be used to position a Bulkhead Fitting in the tank. Any tools or methods that accomplish the task are acceptable.
1. Drill holes as required.
 2. Use a sharp knife, sandpaper, and other tools as required to smooth both sides of each hole to create a smooth sealing surface.
 3. Thoroughly clean the inside of the tank.
 4. Guide a flexible wire (electrical wire, coat hanger, safety wire, etc.) through the hole in which you are installing a fitting and out the filler neck.
 5. Place the bulkhead fitting (nut removed, and one o-ring installed) over the wire and let it slide through the tank to the hole.
 6. Attach a 3/4" diameter washer to the end of the wire which extends from the filler neck and pull the wire/washer into the tank until the washer contacts the bulkhead fitting and "pushes" it through the hole.
 7. Slide the bulkhead fitting's nut (with o-ring) over the wire and onto the fitting. Tighten the lock nut by turning it counter-clockwise. The wrench flats on the end of the internal fitting allow it to be held with a wrench while the nut is tightened.
 8. Remove the wire and washer from the tank.
 9. It is wise to test the fittings for leaks before installing the tank. If you use air pressure, do not apply more than 5 psi.

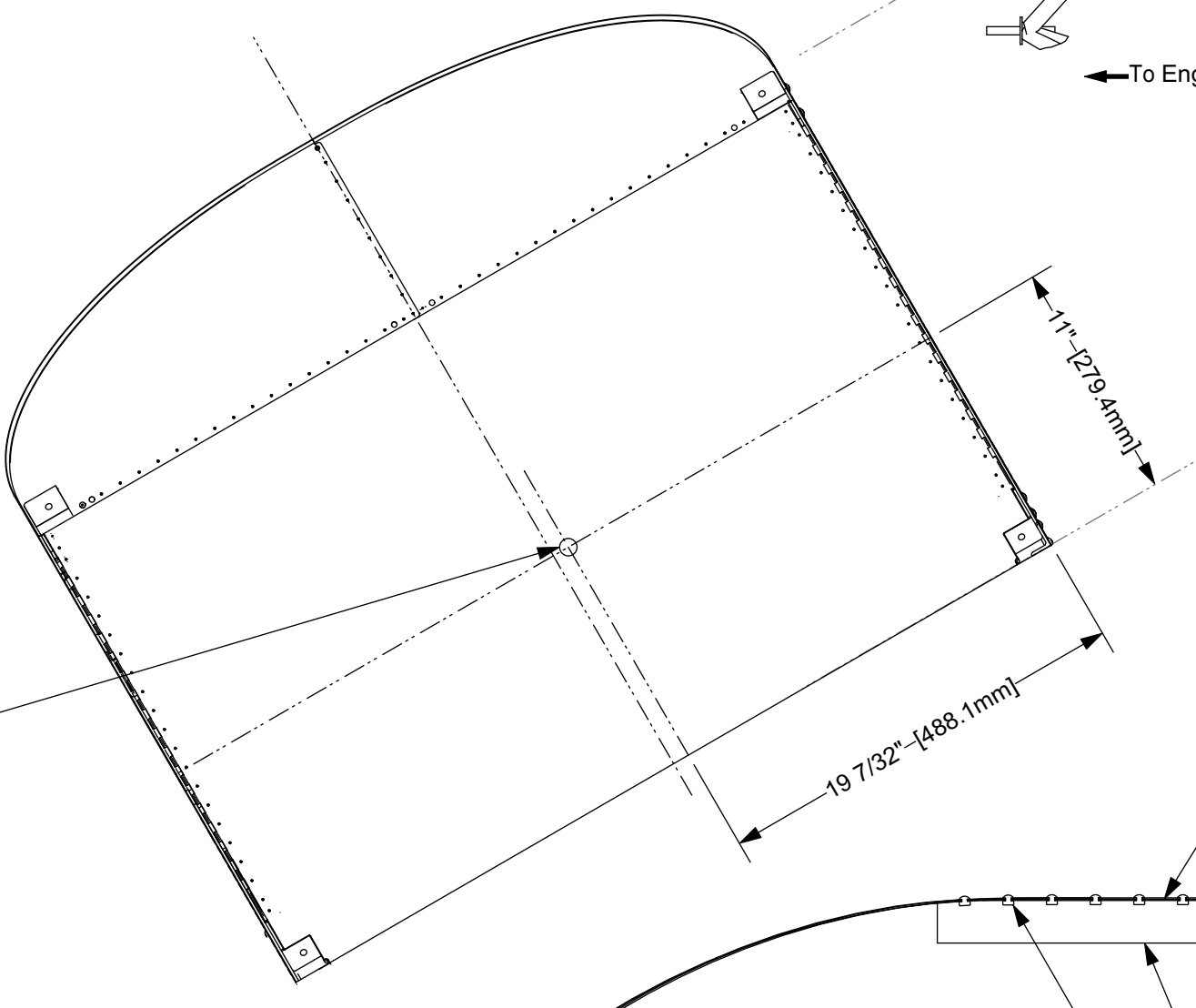

-02 Tank Installation
Scale: 1/4

IMPORTANT: Properly Prepare Tank Before Installing.
See "Preparing and Installing the Fuel Tank."

Section A-A
Detail of Tank Strap Installation
Typical for Aft and Forward Straps
Scale: 1/4

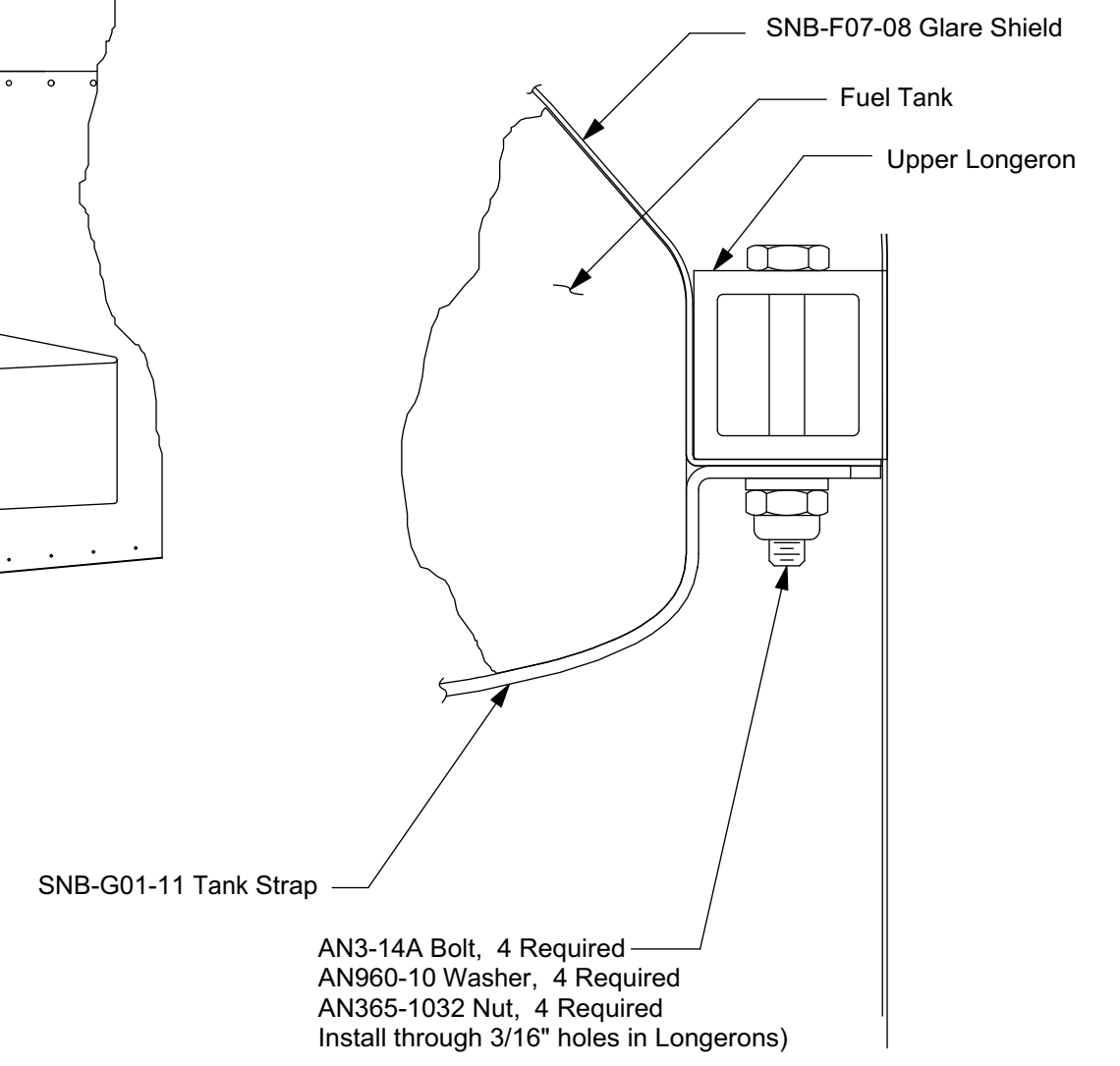

Detail B
Tank Strap Installation
Scale: Full

| Part / Assy Number | Qty. Req'd | Part Title | Next Assembly |
|--------------------|------------|--------------------------|---------------|
| WXB-G01-01 | 1 | Fuel System Installation | WXB-B04 |

waix-B
Fuel System Installation

| Drawing Scale | Drawing Number | Revision |
|---------------|----------------|----------|
| 1/8 & Noted | WXB-G01 | C |