

The information disclosed herein is the property of the originator who reserves all patent, design, proprietary, manufacturing, use and sales rights thereto, except for the rights expressly granted to others. This document shall not be reproduced nor shall the information contained within be used by or disclosed to others except as expressly authorized by the originator.

Revision Letter	Change Description	Revision Date
A	Changed AN525-10R12 bolts through splices and forward lower angle mount to AN525-10R11, and added AN960-10 Washers.	08/24/16
B	Changed from SNB-F18-02LR flap actuator mounts to SNB-F18-03LR feedback actuator mounts for use with feedback-type actuators equipped with potentiometers.	02/10/21
C	Added Notes to View F-F and Detail G to Back-Rivet Actuator Mounts From Interior of Cross-Tie Box.	02/12/21
D	Detail A: AN525-10R12 was AN525-10R11.	02/15/21
E	Changed from SNB-F18-03LR flap actuator mounts to SNB-F18-04LR actuator mounts for use with SNB-C05-11 Flap Actuators, shipped for kits beginning in 2022. NOTE: This change MUST be made to avoid interference of Waiex-B RH Rudder Cable with actuator. Eliminated View E-E, Detail F, and Detail G.	12/19/22

AN525-10R12 Bolt, 4 Required (2 per side)
AN960-10 Washer, 4 Required (2 per side)
AN365-1032 Nut, 4 Required (2 per side)
Thru Fuselage Side Skin, Turtle Deck Skin, Longerons and Splice Plate

Detail A
Scale: 1/2
Typical Right and Left Sides

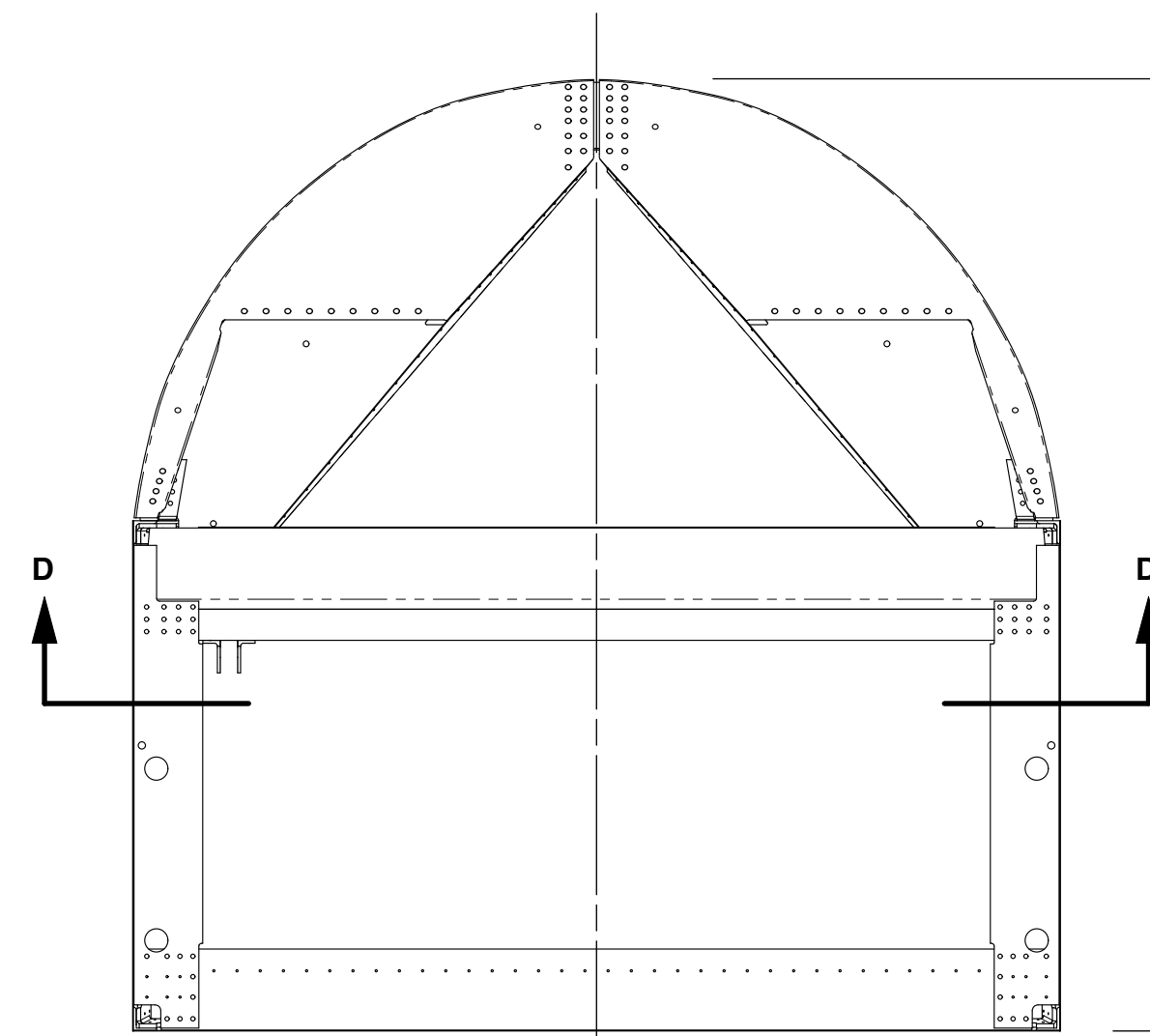

View D-D
View Looking Up at Cross Tie Box
Reference WXB-F24 and WXB-F21 Drawings

SNB-F18-04L
LH Flap Actuator Mount (shown)
SNB-F18-04R
RH Flap Actuator Mount (Opposite -02L)

Cherry CCP-44 Blind Rivets, 16 Required through Cross Tie Box Assembly and Flap Actuator Mounts
Cherry CCP-42 Blind Rivets, 52 Required through Cross Tie Box Assembly
Note: Install rivets after Turtle Deck is installed along with the Fuselage Side Skin rivets and screws

Rivets / Screws along forward edge of Lower Skin installed on later assembly

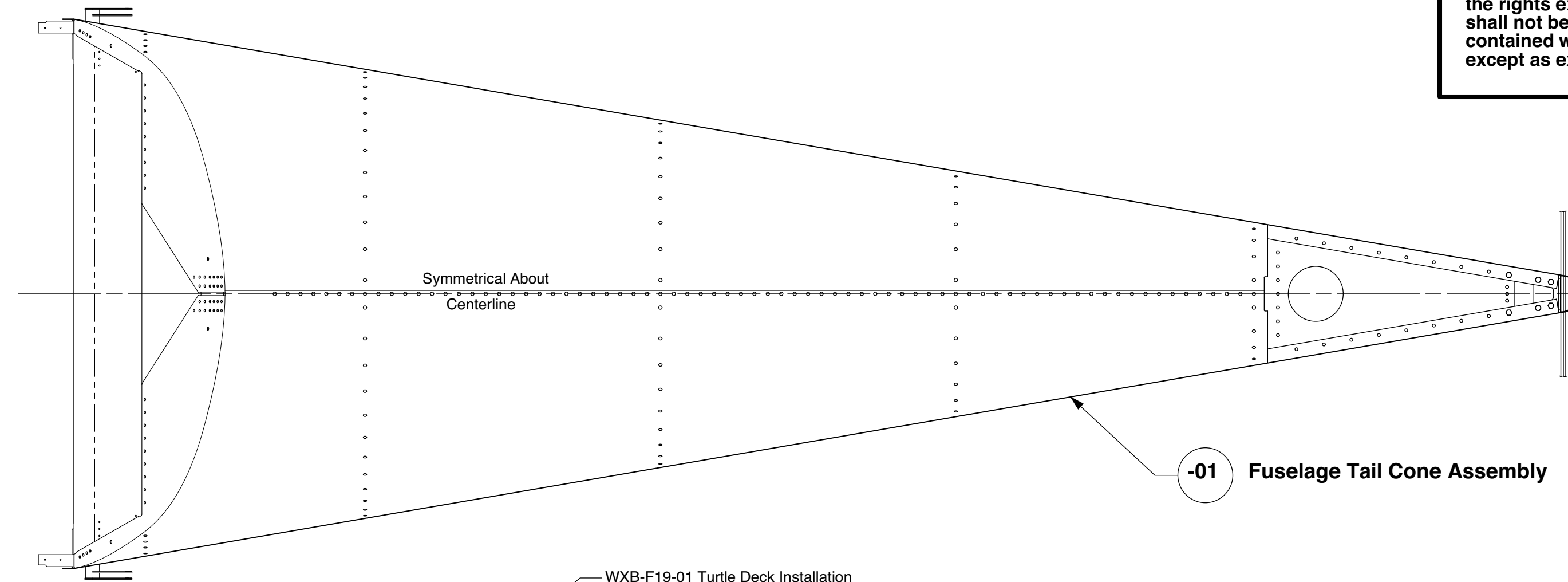

-01 Fuselage Tail Cone Assembly

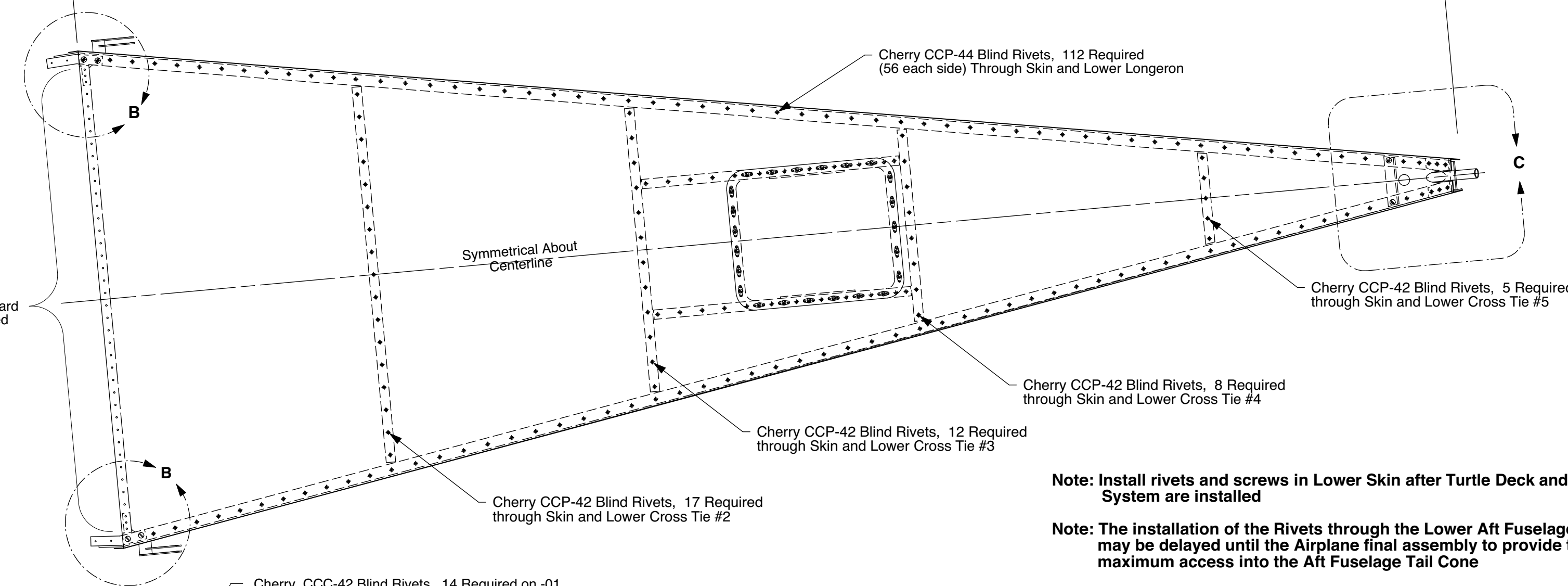
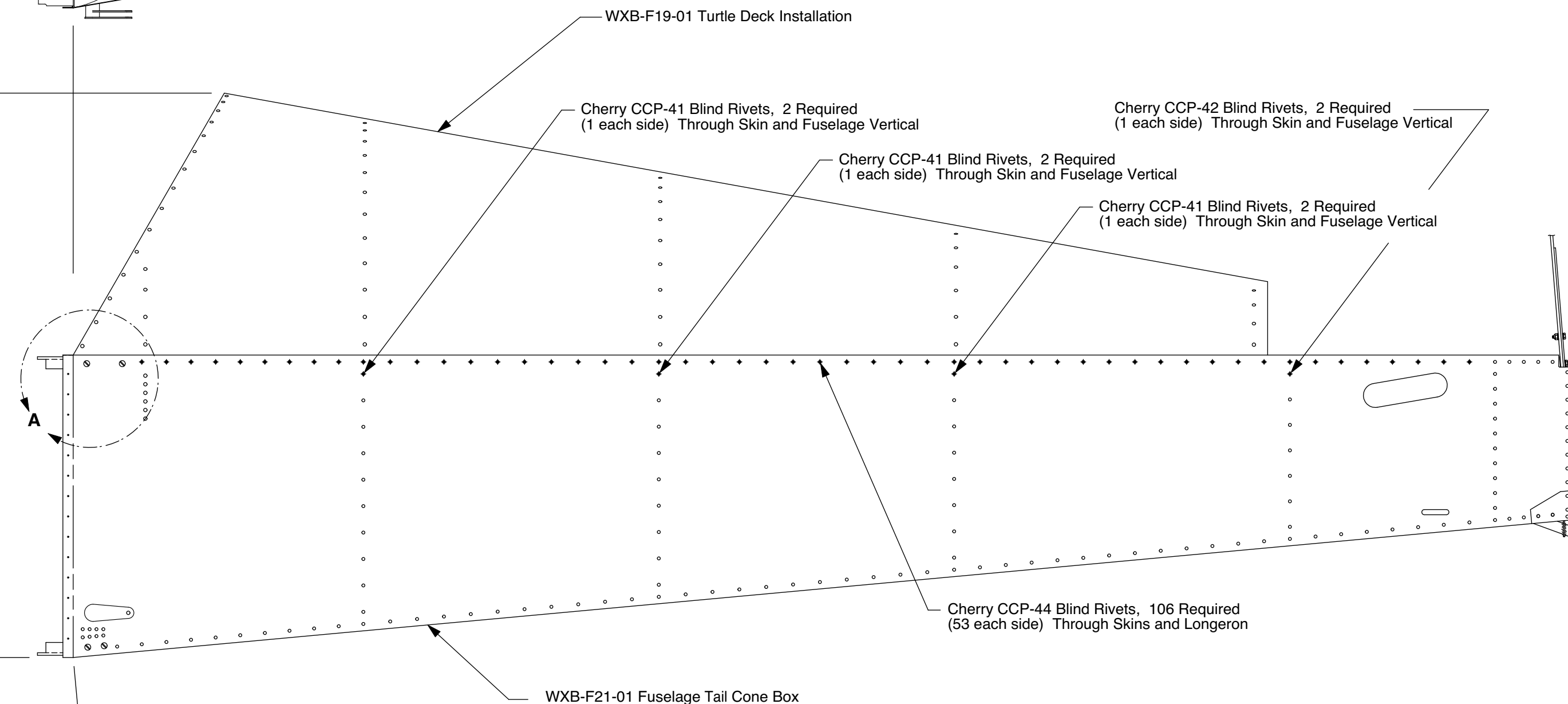

Note: Install rivets and screws in Lower Skin after Turtle Deck and Flap System are installed
Note: The installation of the Rivets through the Lower Aft Fuselage Skin may be delayed until the Airplane final assembly to provide the maximum access into the Aft Fuselage Tail Cone

Cherry CCC-42 Blind Rivets, 14 Required on -01
Typical 14 places for Channel attach rivets under Access Panel
Note: Rivets through Lower Skin and Mount Beams Only

Cherry CCC-42 Blind Rivets, 10 Required
Note: Rivets through Lower Skin and Mount Beams

XNS-F22-03 Access Panel Reference

Detail E
View Looking Up at Bottom Access Panel
Scale 1/4

AN526C-832R6 Machine Screws, 23 Required on -01
MS21047-08 Anchor Nuts, 23 Required on -01
Cherry SSC-32 Flush Blind Rivets, 46 Required on -01
Typical 23 places
Note: Rivets through Lower Skin and Channel and Anchor Nuts only

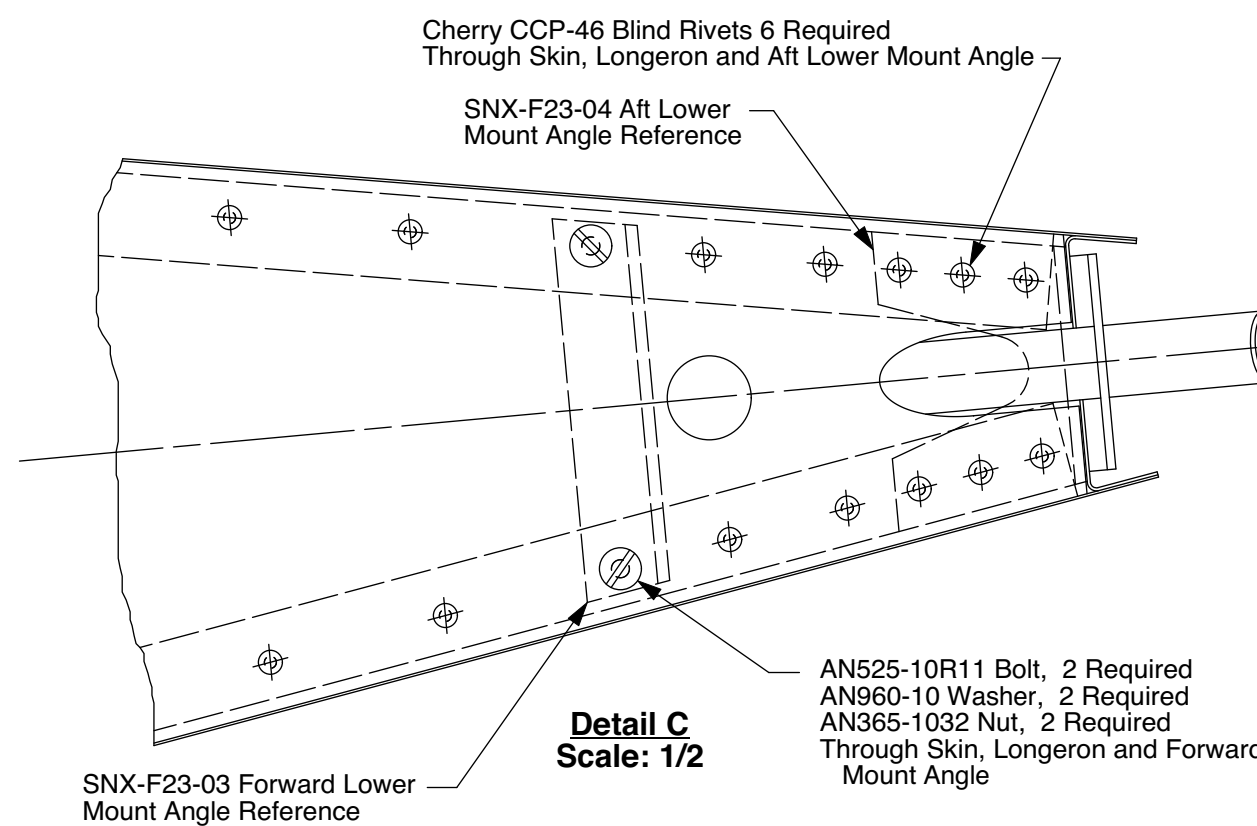

Detail C
Scale: 1/2

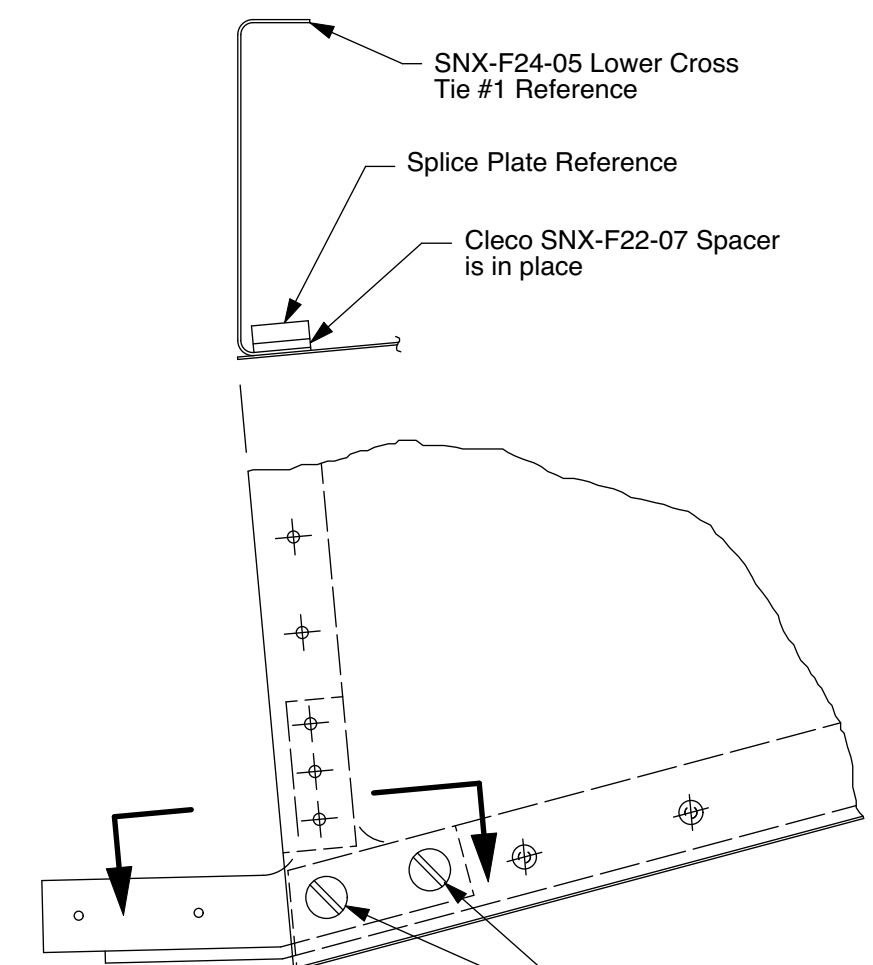

Detail B
Scale: 1/2
Typical Right and Left Sides

Part / Ass'y Number	Qty. Req'd	Part Title	Next Assembly
WXB-F18-01	1	Fuselage Tail Cone Assembly	WXB-F11

waiex-B
Fuselage Tail Cone Assembly

Drawing Scale 1/8 & Noted	Drawing Number WXB-F18	Revision E
------------------------------	---------------------------	---------------