

The information disclosed herein is the property of the originator who reserves all patent, design, proprietary, manufacturing, use and sales rights thereto, except for the rights expressly granted to others. This document shall not be reproduced nor shall the information contained within be used by or disclosed to others except as expressly authorized by the originator.

Revision Letter	Change Description	
A	Added Slot dimensions to ONX-F11-03L	4.9.12
B	Added dimensions and changed hole layout on Details -03R and -03L	10.8.12

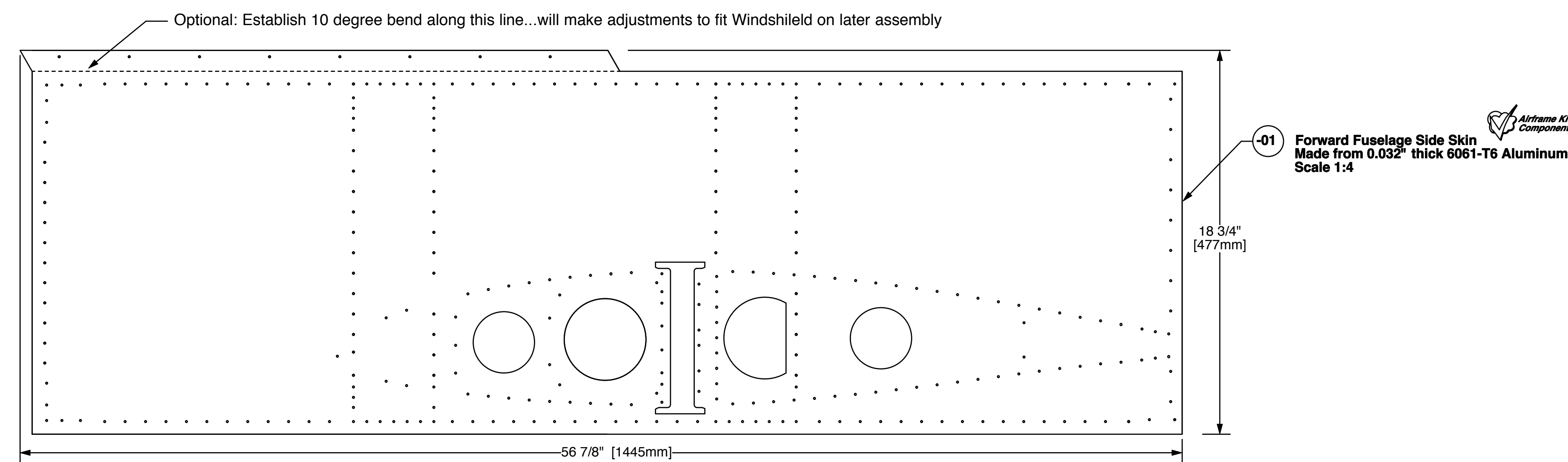
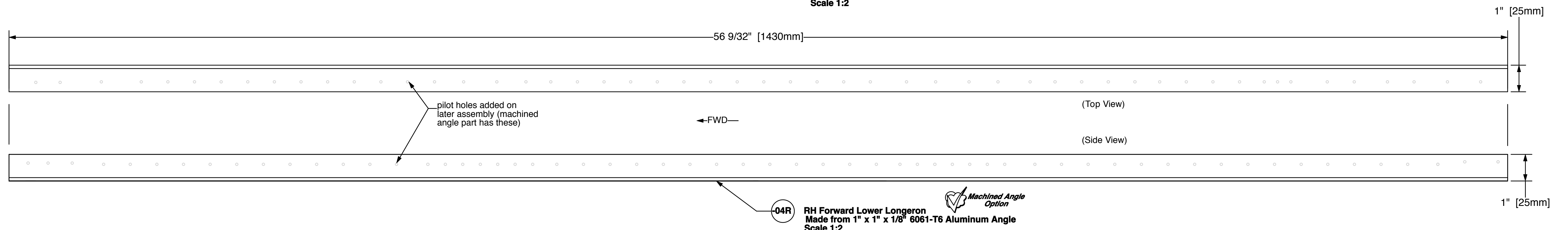
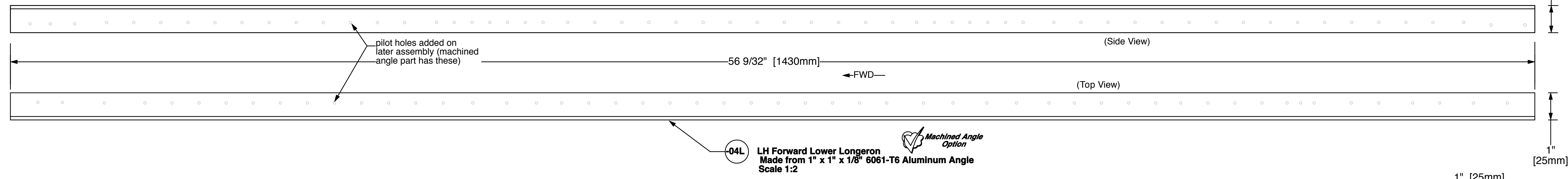
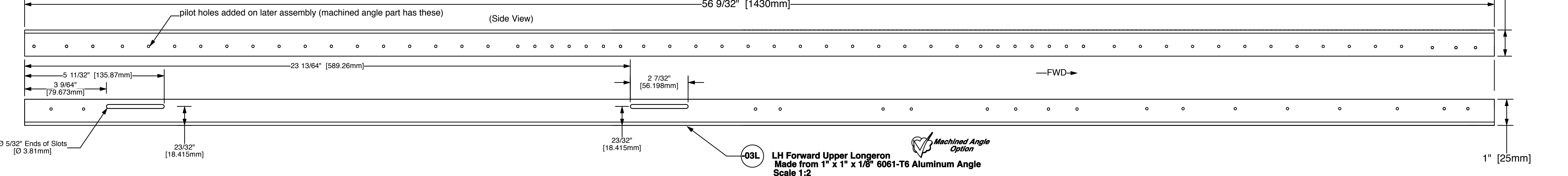
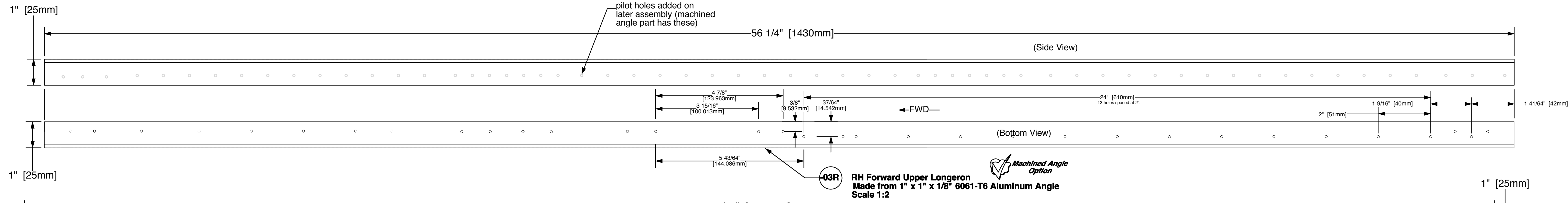

-04R	1	RH Forward Lower Longeron	ONX-F10
-04L	1	LH Forward Lower Longeron	ONX-F10
-03R	1	RH Forward Upper Longeron	ONX-F10
-03L	1	LH Forward Upper Longeron	ONX-F10
-01	2	Forward Fuselage Side Skin	ONX-F10
Dash Number	Quantity Required	Part Title	Next Assembly

onex
Fuselage Forward Side Panel, Longerons, and Skin

Drawing Scale	Drawing Number	Revision
None	ONX-F11	B