

The information disclosed herein is the property of the originator who reserves all patent, design, proprietary, manufacturing, use and sales rights thereto, except for the rights expressly granted to others. This document shall not be reproduced nor shall the information contained within be used by or disclosed to others except as expressly authorized by the originator.

Revision Letter	Change Description	
A	Removed upgrade details when the electric flaps became standard equipment. Added Warning Lights Wire Diagram.	2.6.19
B	Added wiring schematics for Flap Actuator Motor and Potentiometer.	4.8.20
C	Detail B: Jam nut was AN365-428. Call-out for Detail D was Detail E. Detail C: Castle nut was AN310-3.	8.4.20
D	<b>Flap Actuator Change for Aircraft Serial Numbers JSX0052 and Later.</b> <b>Detail A:</b> - Replaced JSX-C03-64L with JSX-C03-70L Left Hand Flap Actuator Mount. - Replaced JSX-C03-64R with JSX-C03-70R Right Hand Flap Actuator Mount. <b>Detail B:</b> - Replaced JSX-C03-67 with JSX-C03-71 Flap Actuator. - Replaced JSX-C03-61 with JSX-C03-68 Electric Flap Push Rod. - Replaced JSX-C03-63 with JSX-C03-69 Electric Flap Actuator Switch Mount and Mounting Hardware. <b>Detail C:</b> - Updated Visual Depiction to show new JSX-C03-71 Flap Actuator installation. - Replaced AN4-13 with AN4-16 Bolt. <b>Detail F:</b> - Updated Potentiometer Wire Colors for JSX-C03-71 Flap Actuator.	05.08.23

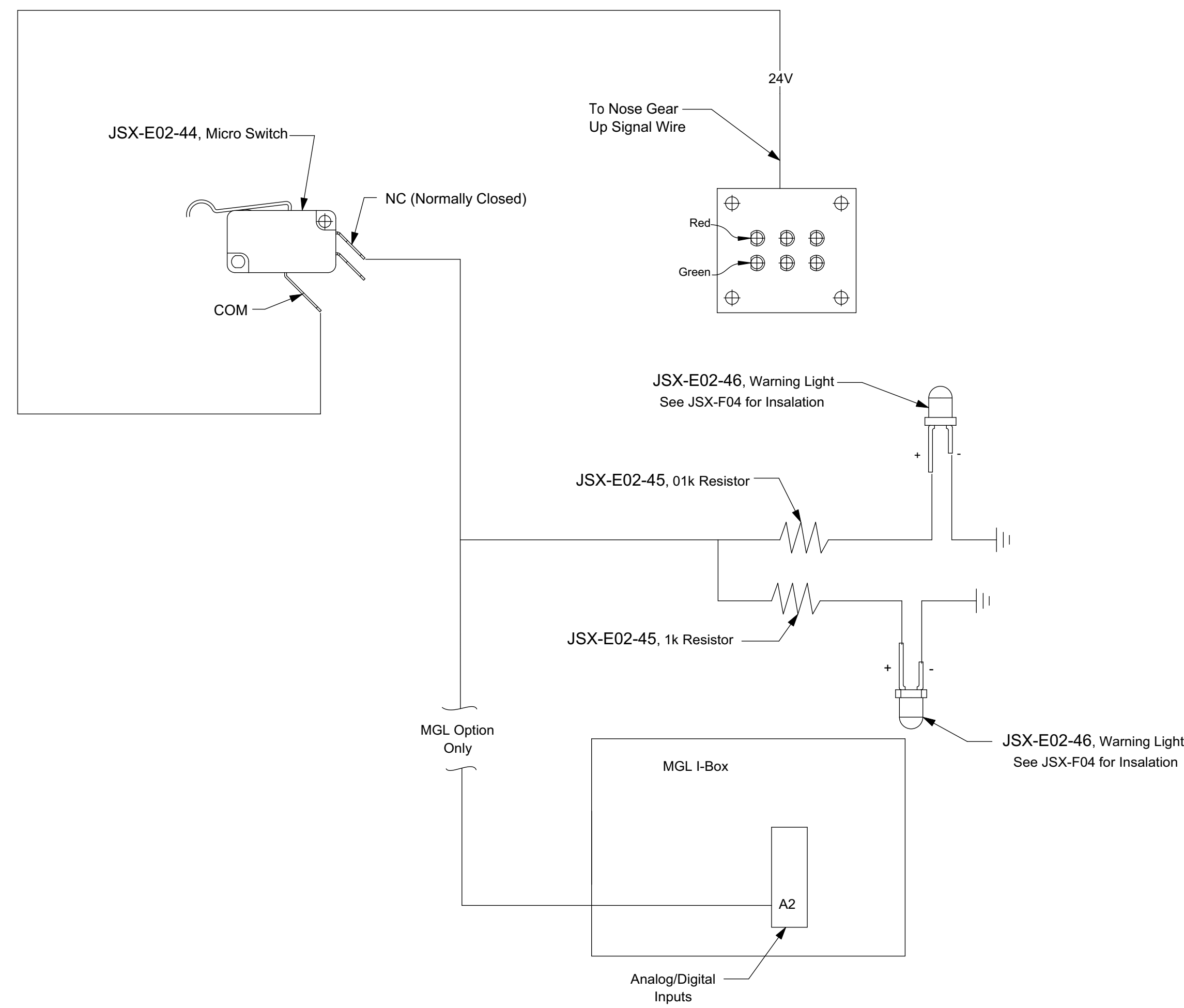

**Detail E**  
Warning Lights Wire Diagram

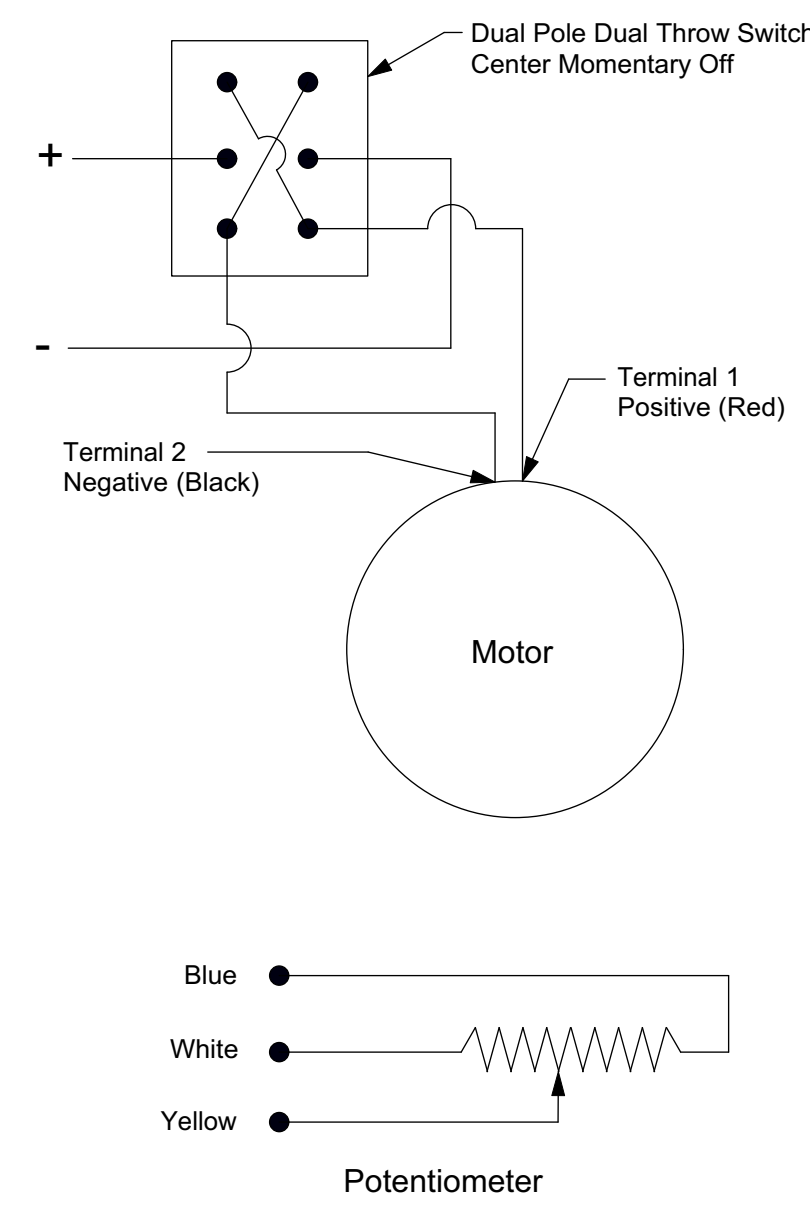

**Detail F**  
Flap Actuator Wiring Schematic

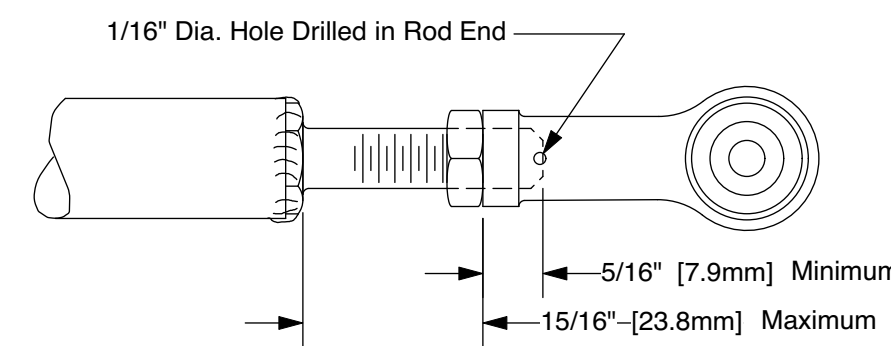

**Detail D**  
Minimum Thread Engagement for Rod End Control Pushrod Threads MUST Extend to Witness Hole for Proper Installation

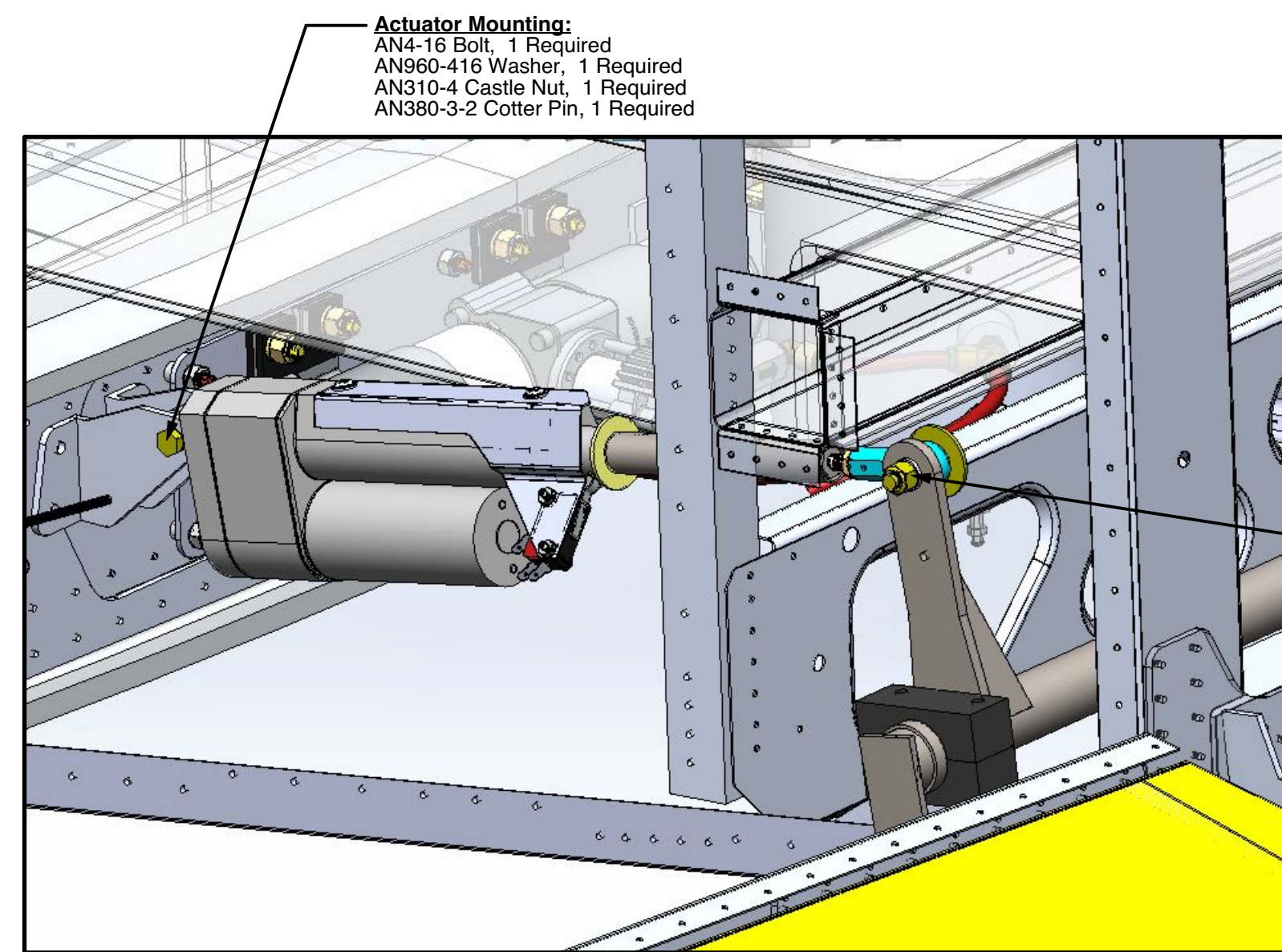

**Detail C**  
Flap Actuator and Rod Assembly Installation

**Actuator Mounting:**  
AN4-16 Bolt, 1 Required  
AN960-416 Washer, 1 Required  
AN310-4 Castle Nut, 1 Required  
AN380-3-2 Cotter Pin, 1 Required

**Actuator to Flap Drive Tube:**  
AN4-10A Bolt, 1 Required  
AN970-416 Large Washer, 1 Required  
AN960-416 Washer, 1 Required  
AN365-428 Nut, 1 Required

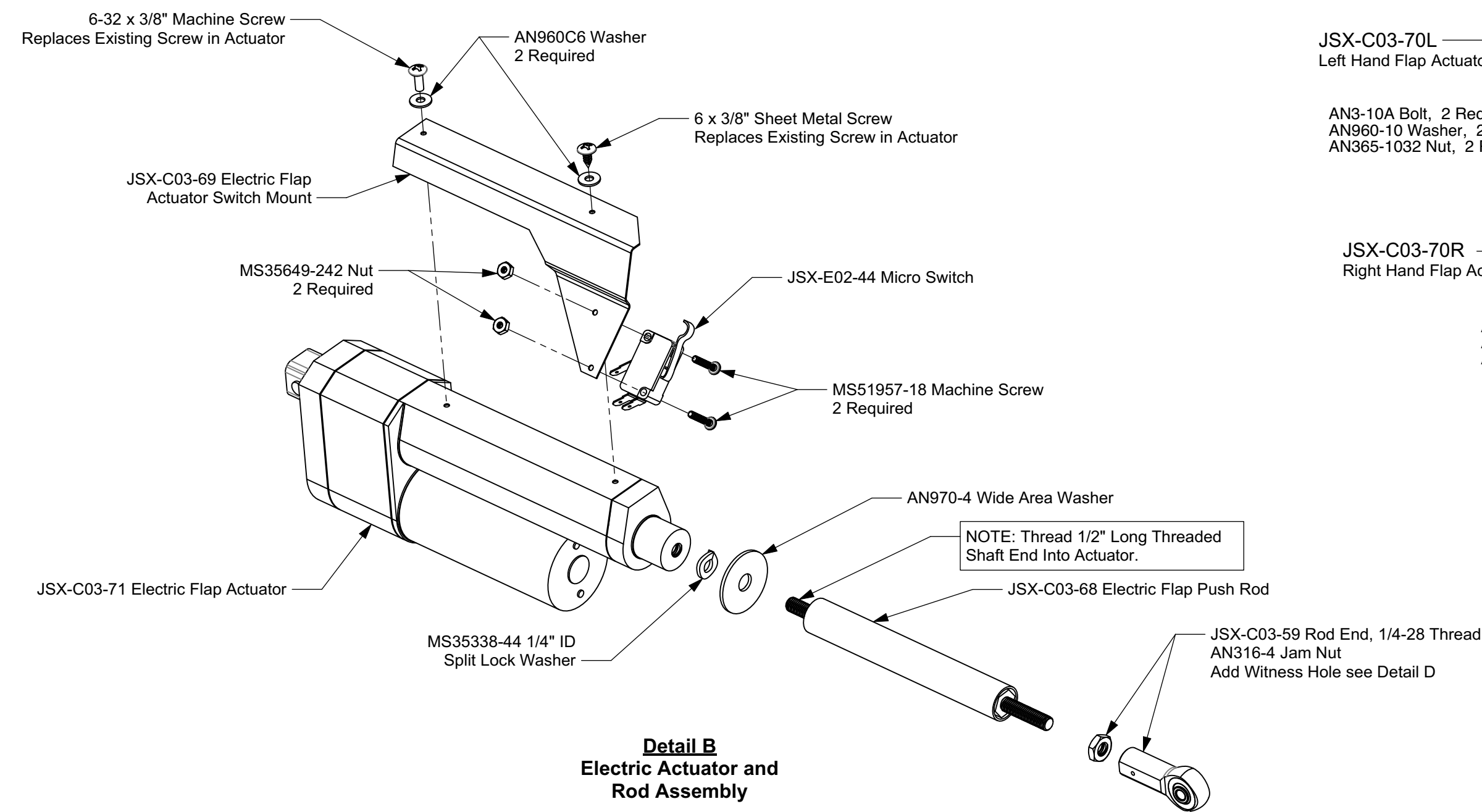

**Detail B**  
Electric Actuator and Rod Assembly

1/4" I.D. x 3/8" O.D. x 3/16" Long Sintered Bronze Oil Impregnated Flanged Bushing (SYMMCO # SF-812-3 or equal) 2 Required

JSX-C03-70L Left Hand Flap Actuator Mount  
AN3-10A Bolt, 2 Required  
AN960-10 Washer, 2 Required  
AN365-1032 Nut, 2 Required

JSX-C03-70R Right Hand Flap Actuator Mount  
AN3-5A Bolt, 2 Required  
AN960-10 Washer, 2 Required  
AN365-1032 Nut, 2 Required

**Detail A**  
Aft View of Main Spar LH Side with Electric Flap Mounts Installed

Dash / Part Number	Qty Req'd	Part Title	Next Assembly
<b>SubSonex</b> Electric Flap Installation			
Drawing Scale	Drawing Number	Revision	
None	JSX-C06	D	