

The information disclosed herein is the property of the originator who reserves all patent, design, proprietary, manufacturing, use and sales rights thereto, except for the rights expressly granted to others. This document shall not be reproduced nor shall the information contained within be used by or disclosed to others except as expressly authorized by the originator.

Revision Letter	Change Description
-----------------	--------------------

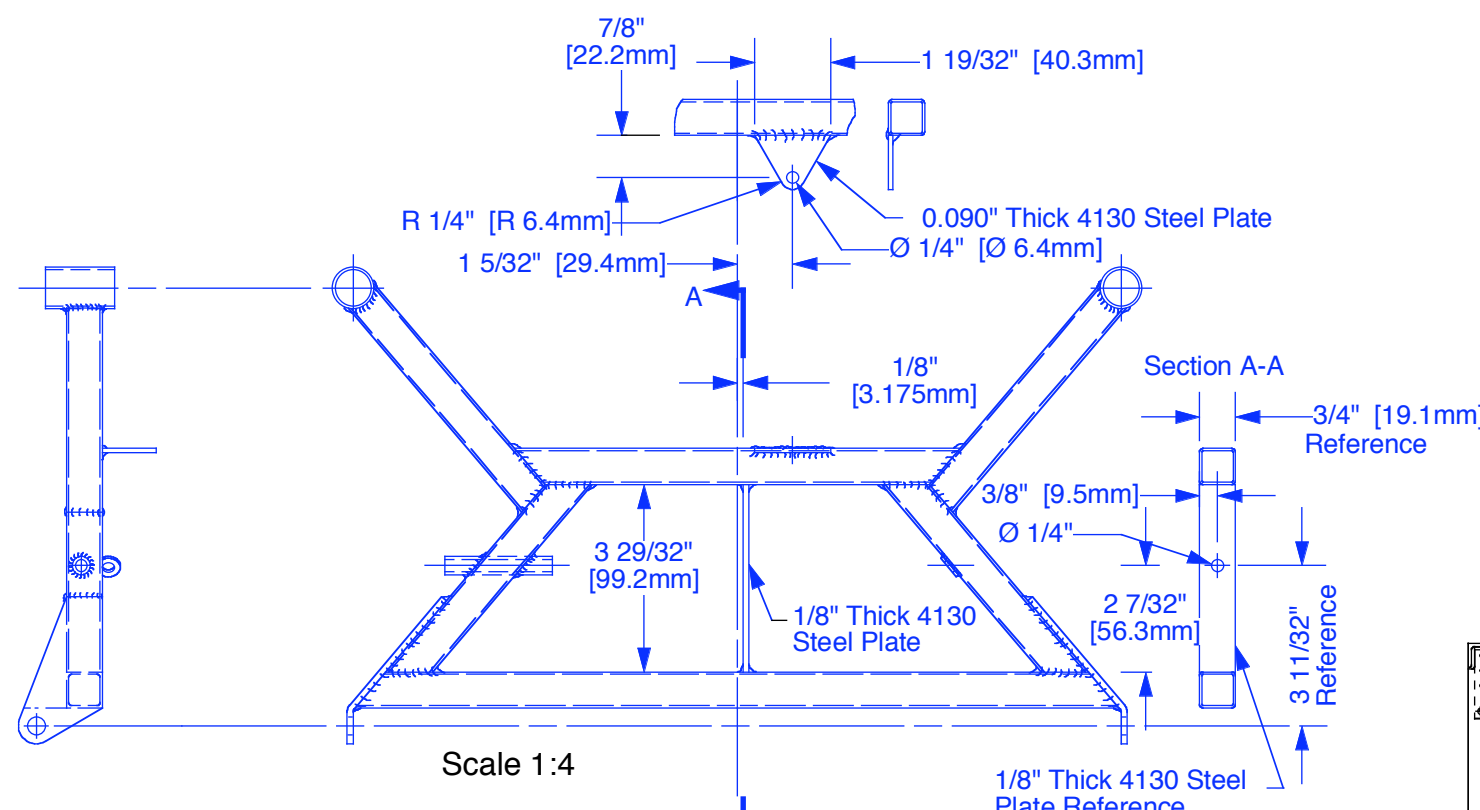

SNX-C05-08 Control Stick Frame Assembly for Lowered Seat
1 Required on -01, Weld Frame Assembly together using number 7 welding rod

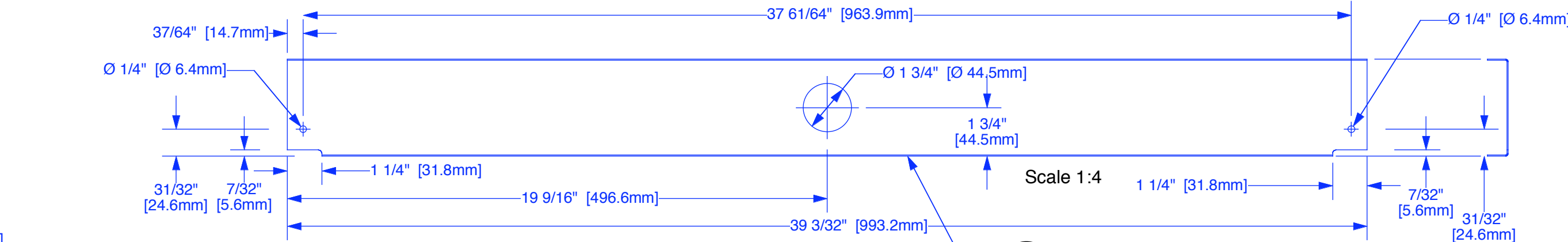

(Replaces SNX-F03-02 Channel)
Channel, 1 Required on -01
Make from SNX-Z04-03 3 1/2\" Channel Stock (40\" [1016mm] long)

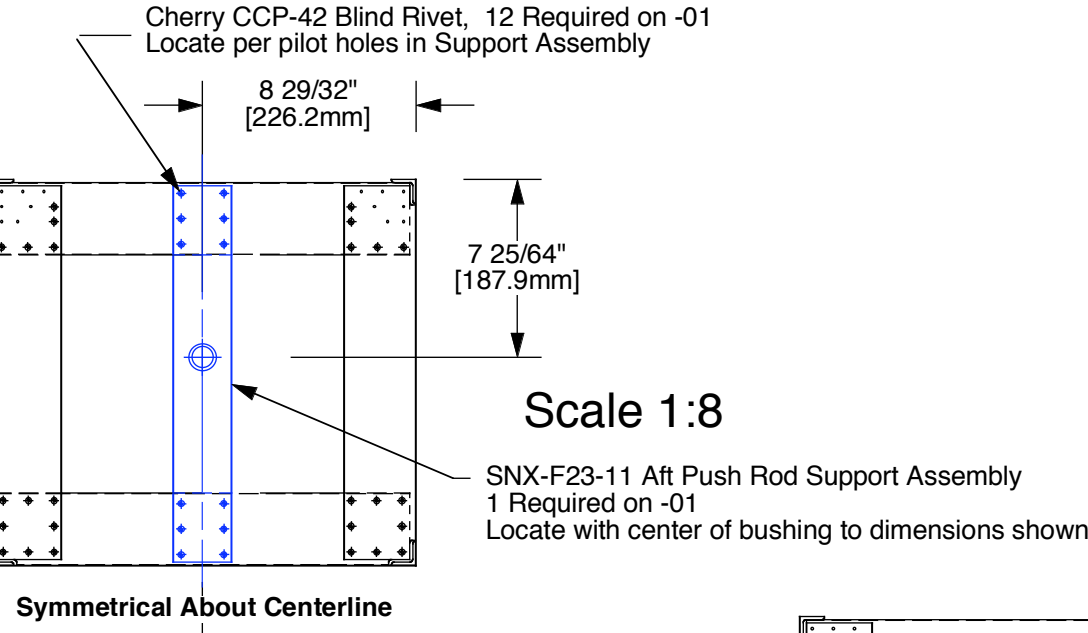

Scale 1:8

Section N-N
View Looking Aft at Push Rod Support

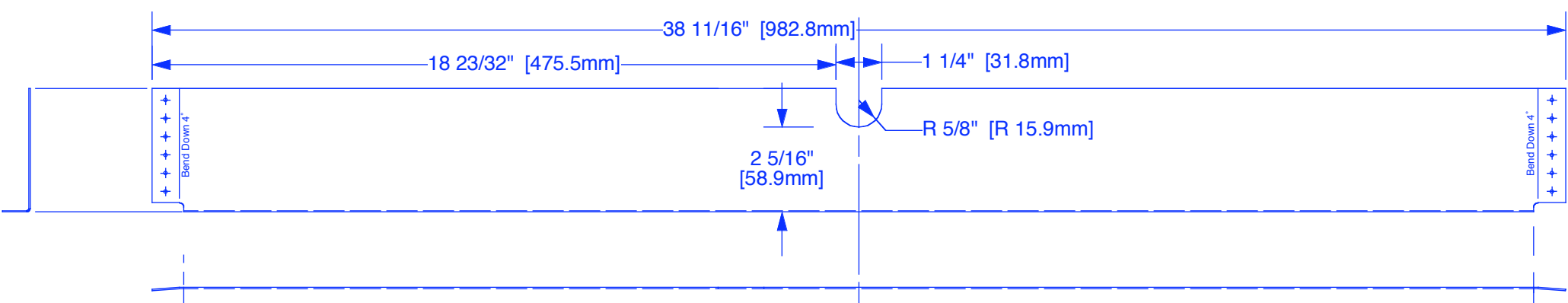

-05 Angle (Refer to SNX-F10-01 for all dimensions not given on this view)
Make from SNX-Z04-03 3 1/2\" Channel Stock
Remove Flange 1 side to make Angle

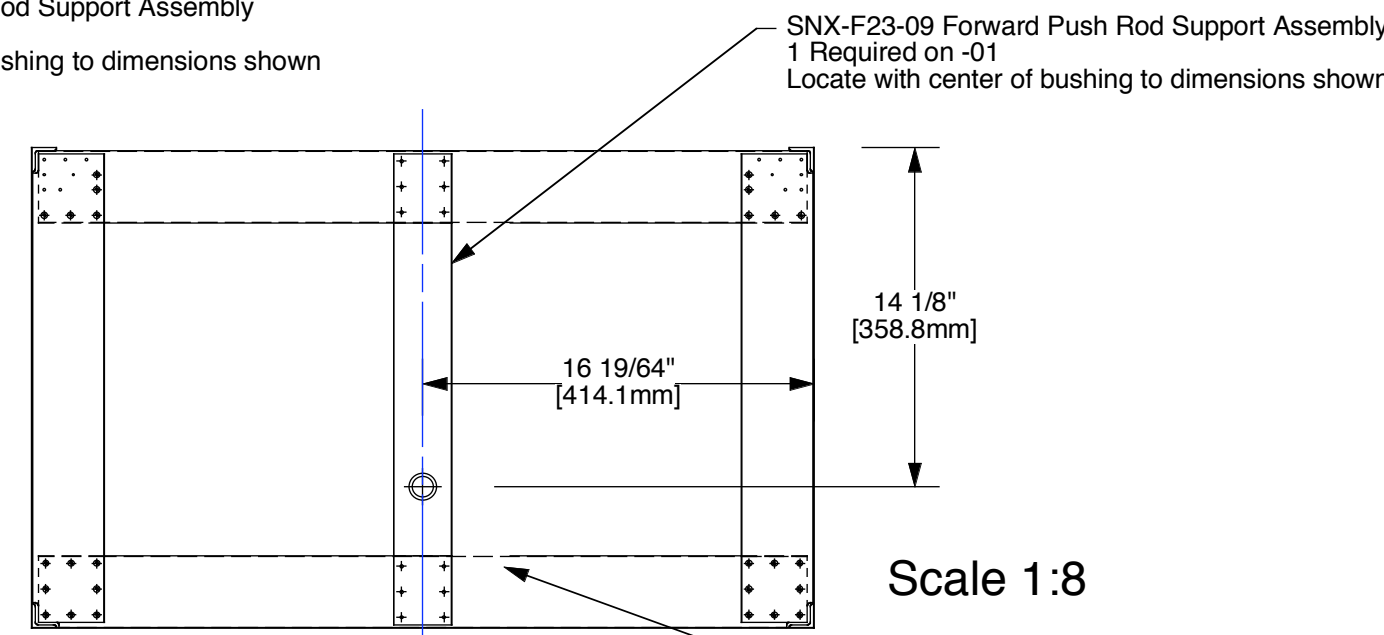

Scale 1:8

Section P-P
View Looking Aft at Push Rod Support

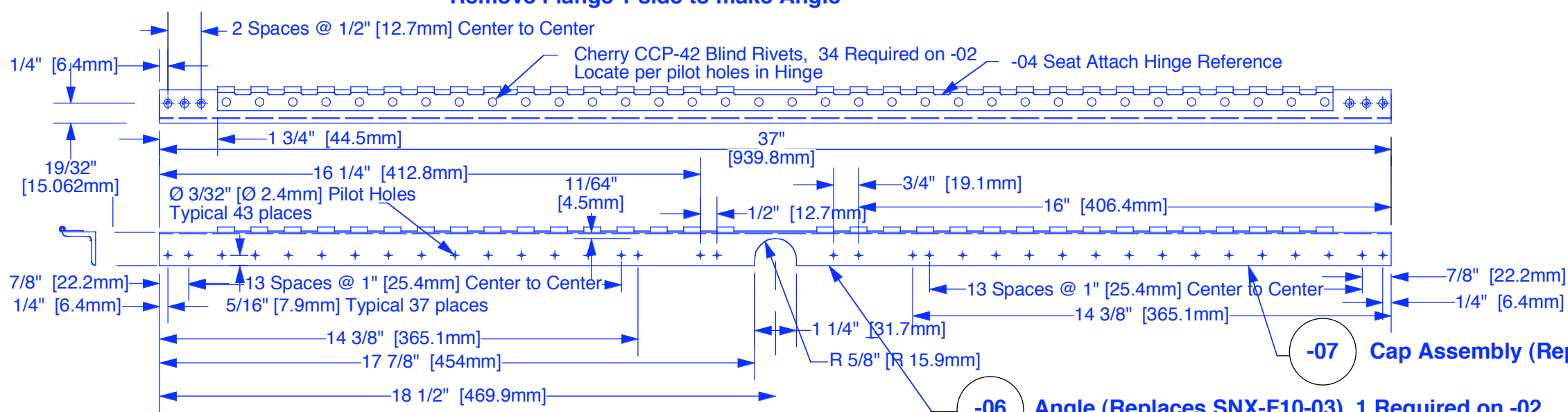

-07 Cap Assembly (Replaces SNX-F10-02)

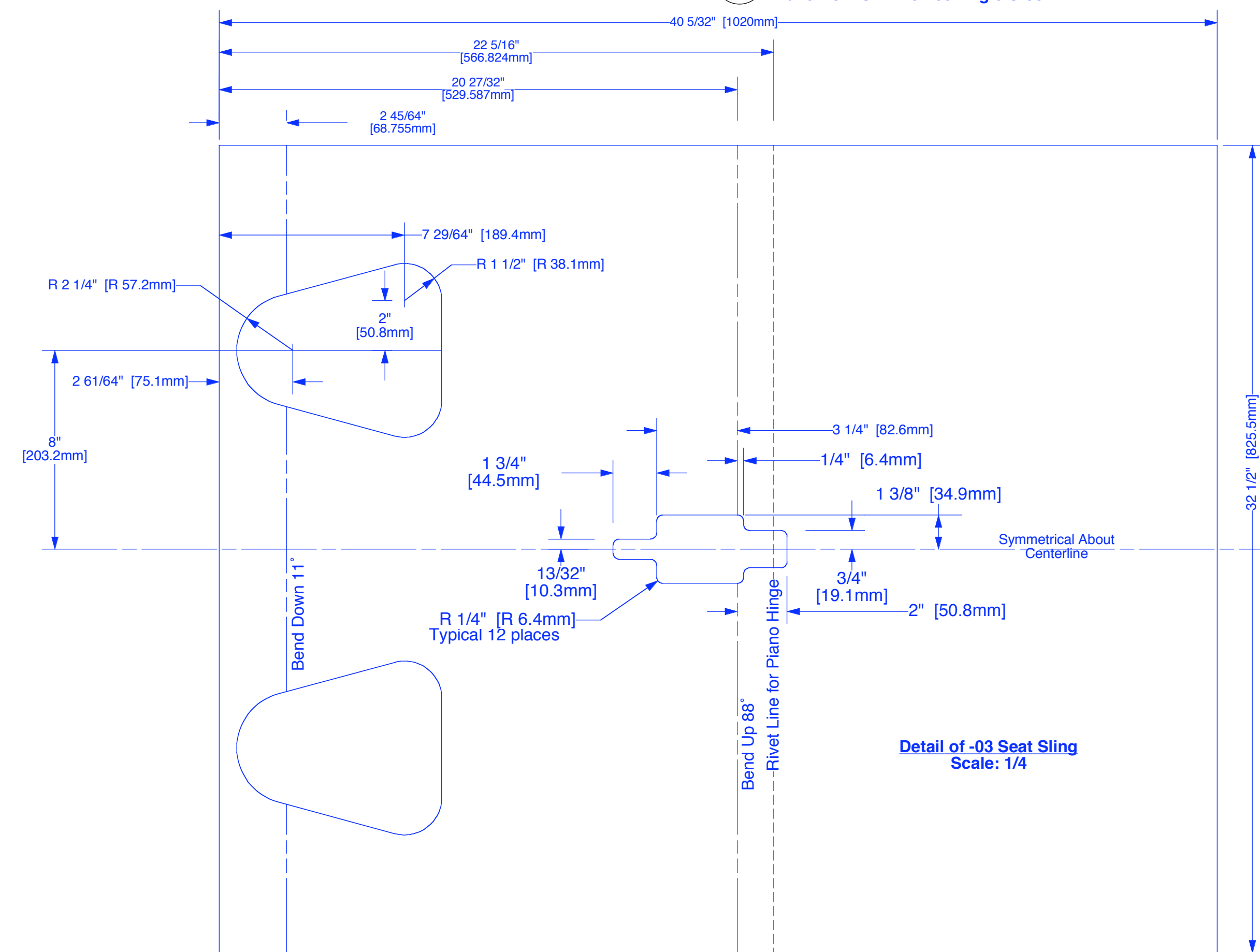

-03 Dropped Seat Sling, 1 Required on -01
.025\" Thick 6061-T6 Aluminum Sheet
1/16\" [1.6mm] Bend Radius

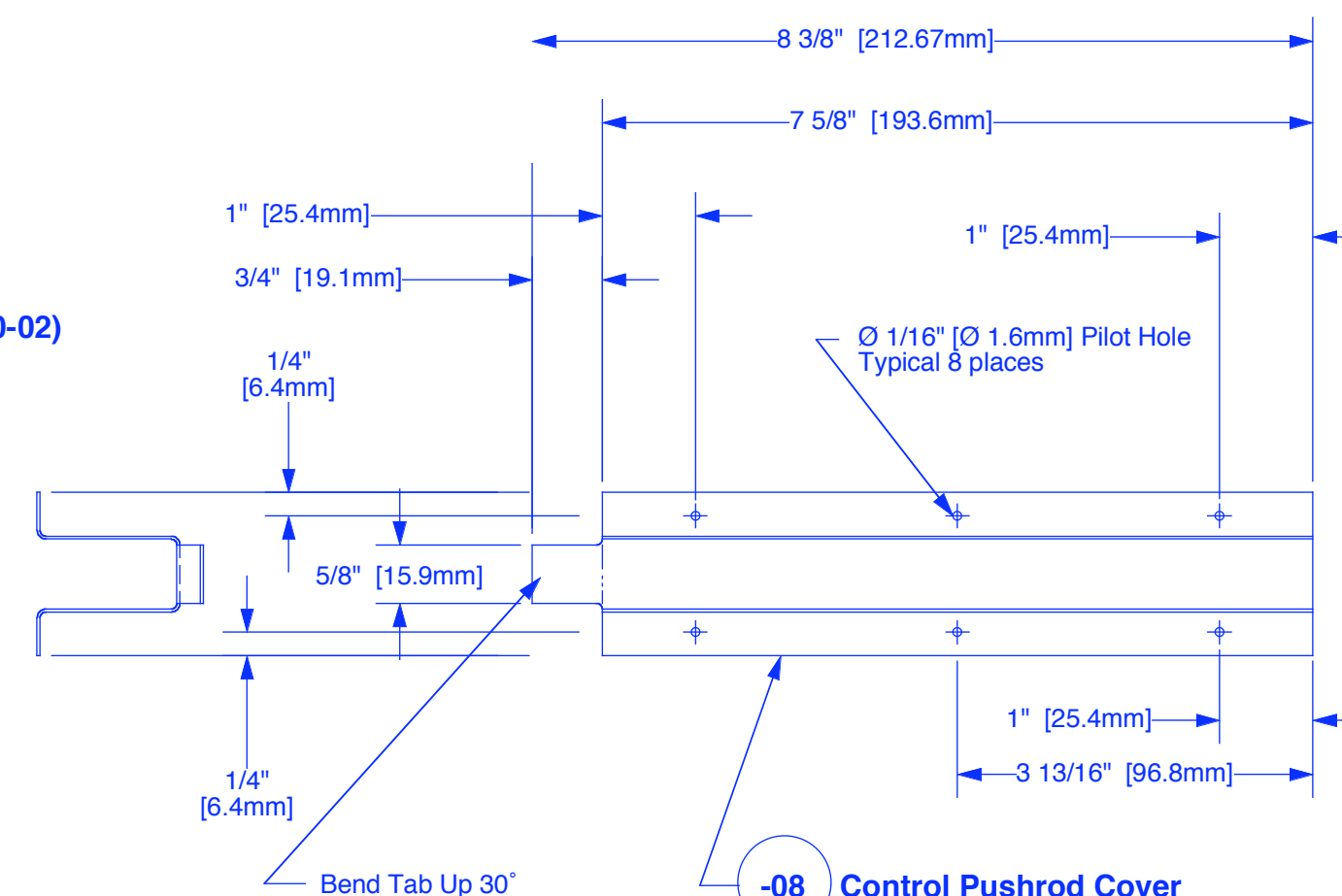

-08 Control Pushrod Cover
1 Required on -01
Make from XNS-Z04-01 Hat
(Hat Section Available for Purchase from Sonex)

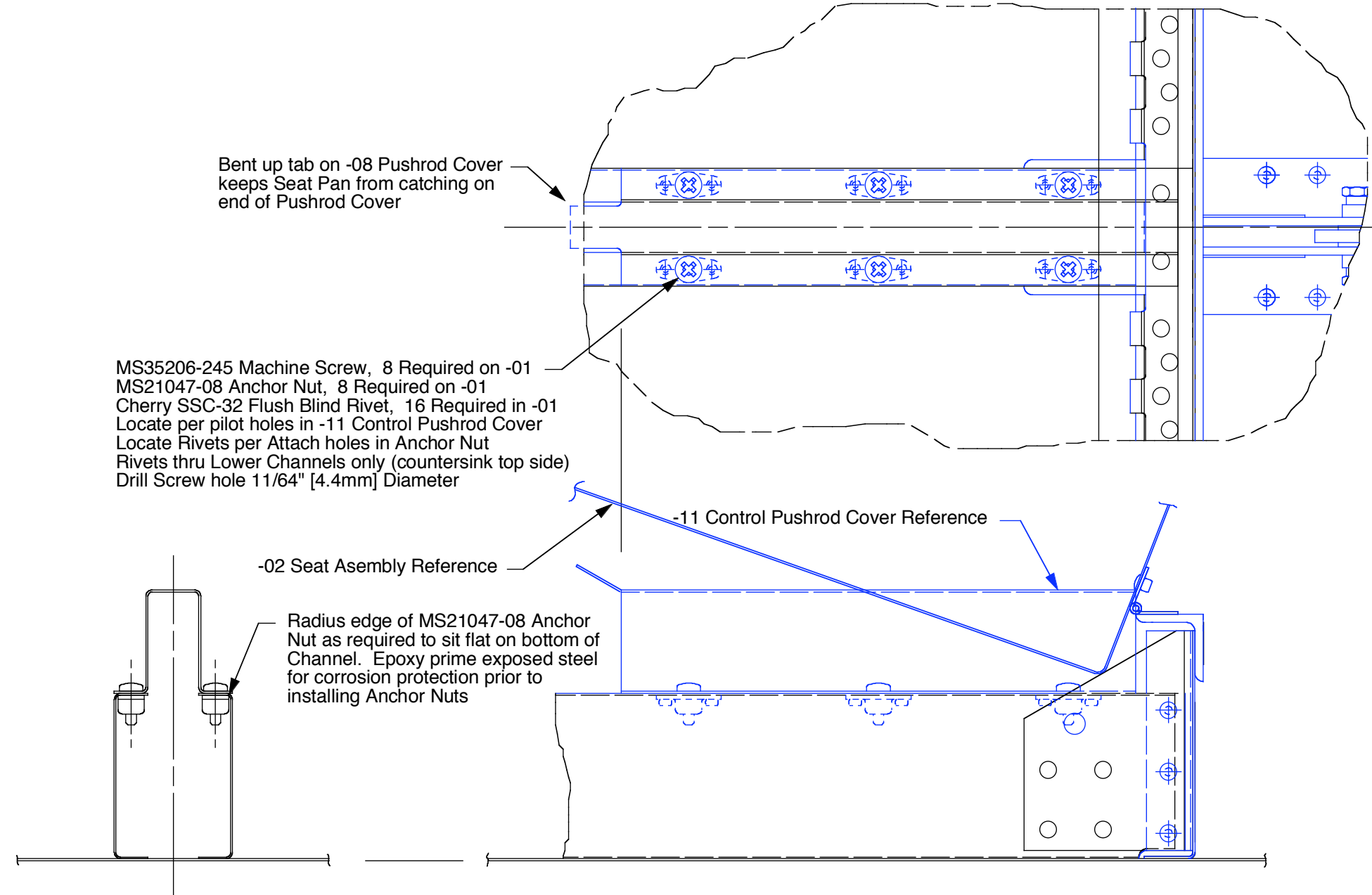

Scale 1:2

Section H-H
Note: Top View shown without
Seat Pan for clarity

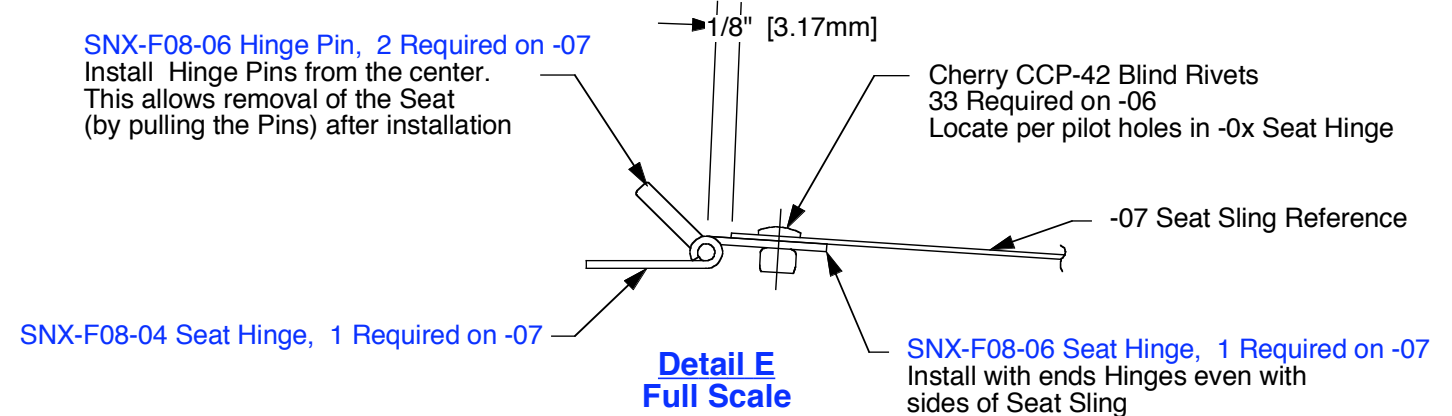
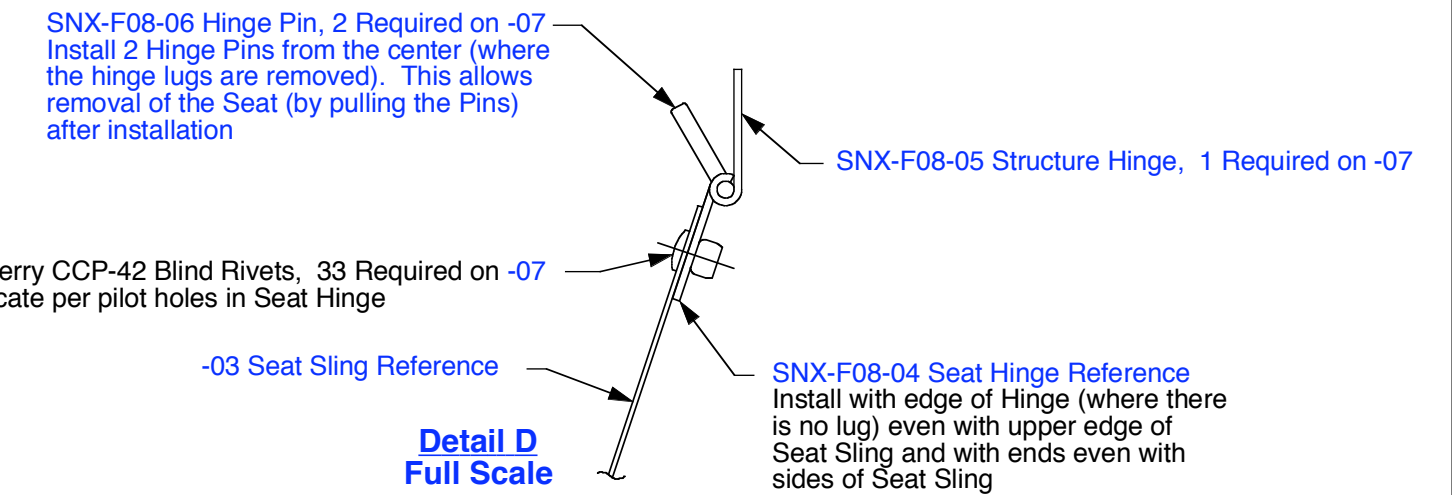
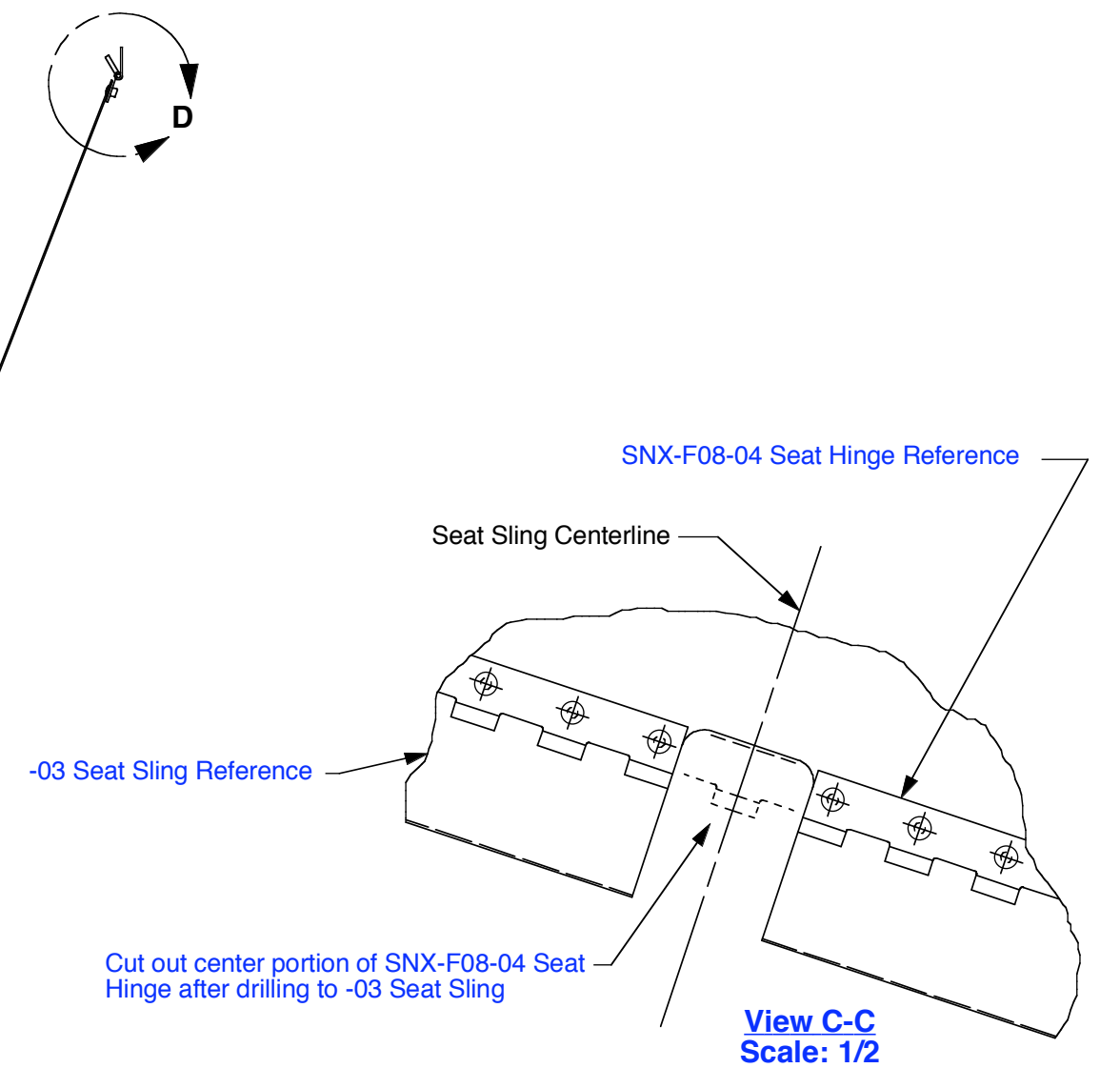

Note: Building the Aircraft with the Optional Dropped Seat

The Optional Dropped Seat is not called out in the sonex Drawing System. To Build the Aircraft with the optional Dropped Seat the following revisions must be made on the following drawings:

Note that the Dropped Seat can only be installed using the Daul Stick Controls.

SNX-C05 Optional Dual Stick Details & Assembly.

Modify the Control Stick Frame per the detail on this drawing. SNX-C05-02 Control Stick Frame becomes SNX-C05-08 after modification.

Delete SNX-C05-04 Seat Sling
Replace with SNX-C06-03 Seat Sling for Lowered Seat Mod called out on this page.

SNX-F03-01 Rear Spar Carry Through

Delete SNX-F03-02 Channel
Replace with SNX-C06-04 Channel w/ hole in center called out on this page.
Pictorial Change: Modify SNX-F03-01 Assembly to show hole in the center.

SNX-F09 Aft Lower Cabin Detail Installation

Delete Drawing SNX-F09 Aft Lower Cabin Detail Installation
Replace with SNX-C07 Aft Lower Cabin Detail Installation for Lowered Seat Modification

SNX-F10 Aft Lower Cabin Details

Delete SNX-F10-01 Angle
Replace with SNX-C06-05 Angle w/notch in center called out on this page.

Delete SNX-F10-02 Cap Assembly and SNX-F10-03 Angle.
Replace with SNX-C06-06 Angle w/ notch in center and SNX-C06-07 Assembly called out on this page.

SNX-F21 Fuselage Tail Cone Box

Replace Details N-N and P-P with Details N-N and P-P called out on this page.
Make New Part SNX-C06-08 Cover and Install per Section H-H.

Dash Number	Quantity Required	Part Title	Next Assembly
sonex			
Optional Lowered Seat Modification			
Details & Assembly			
Drawing Scale	Drawing Number	Revision	
1/4 & Noted	SNX-C06	N/C	