

The information disclosed herein is the property of the originator who reserves all patent, design, proprietary, manufacturing, use and sales rights thereto, except for the rights expressly granted to others. This document shall not be reproduced nor shall the information contained within be used by or disclosed to others except as expressly authorized by the originator.

Revision Letter	Change Description
A	View B-B appeared twice. Changed title of seat belt side fuselage attach to View C-C to match -03 Install Call-out. Detail A. Added SS-1216-4 Bushing Qty 2 View B-B. Added SS-1216-4 Bushing Qty 1 View C-C. Added SS-1216-6 Bushing (3/8 long), Qty 2
B	Added Details -06 and -07 for Blade-Style Seat Belt now supplied with kits. Added views C-C and D-D to show hardware installation for -03 Seat Belt Installation. Changed hardware for -03 Seat Belt Installation. Added Hardware call-outs for -08 Seat Belt Installation. 2.19.13

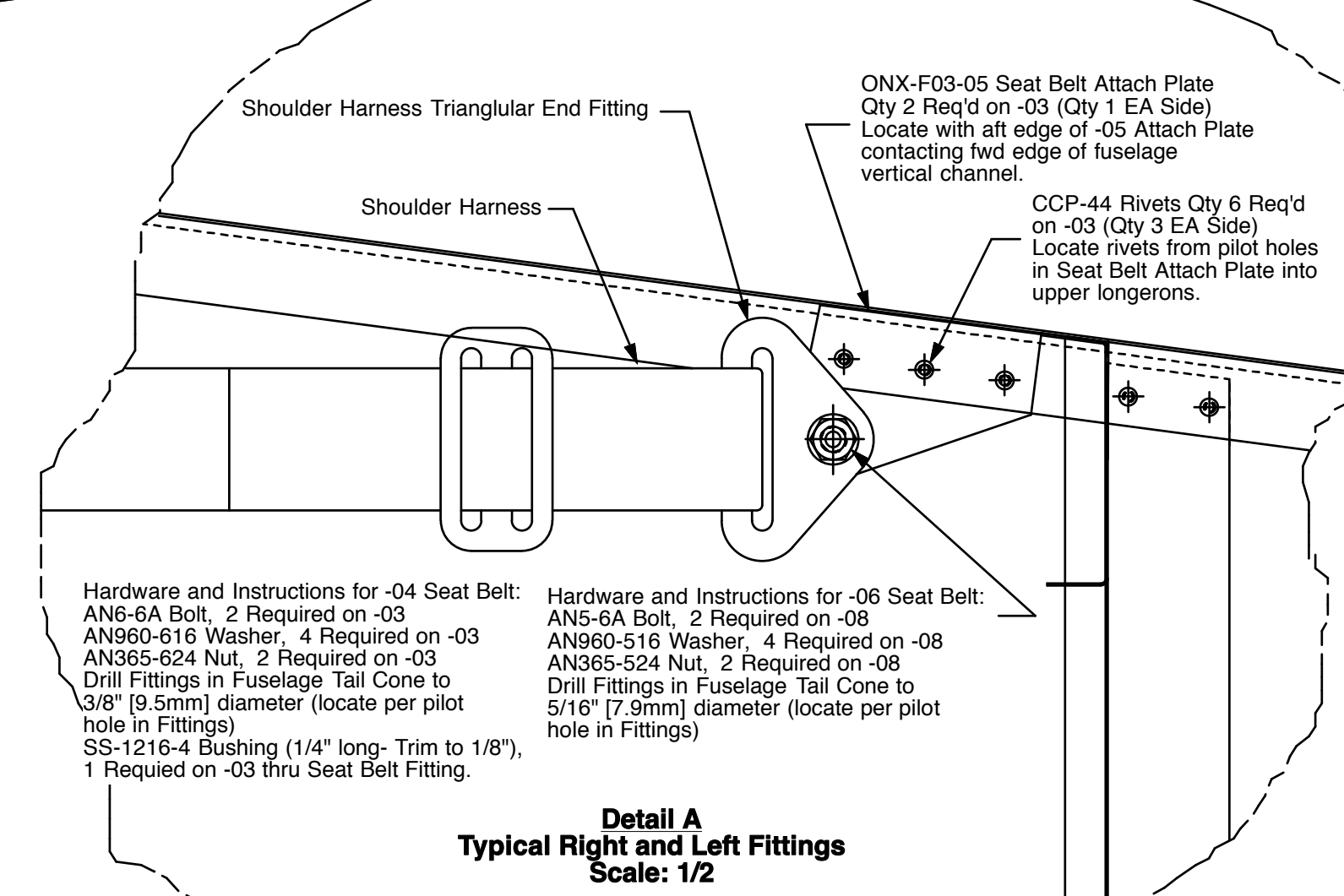
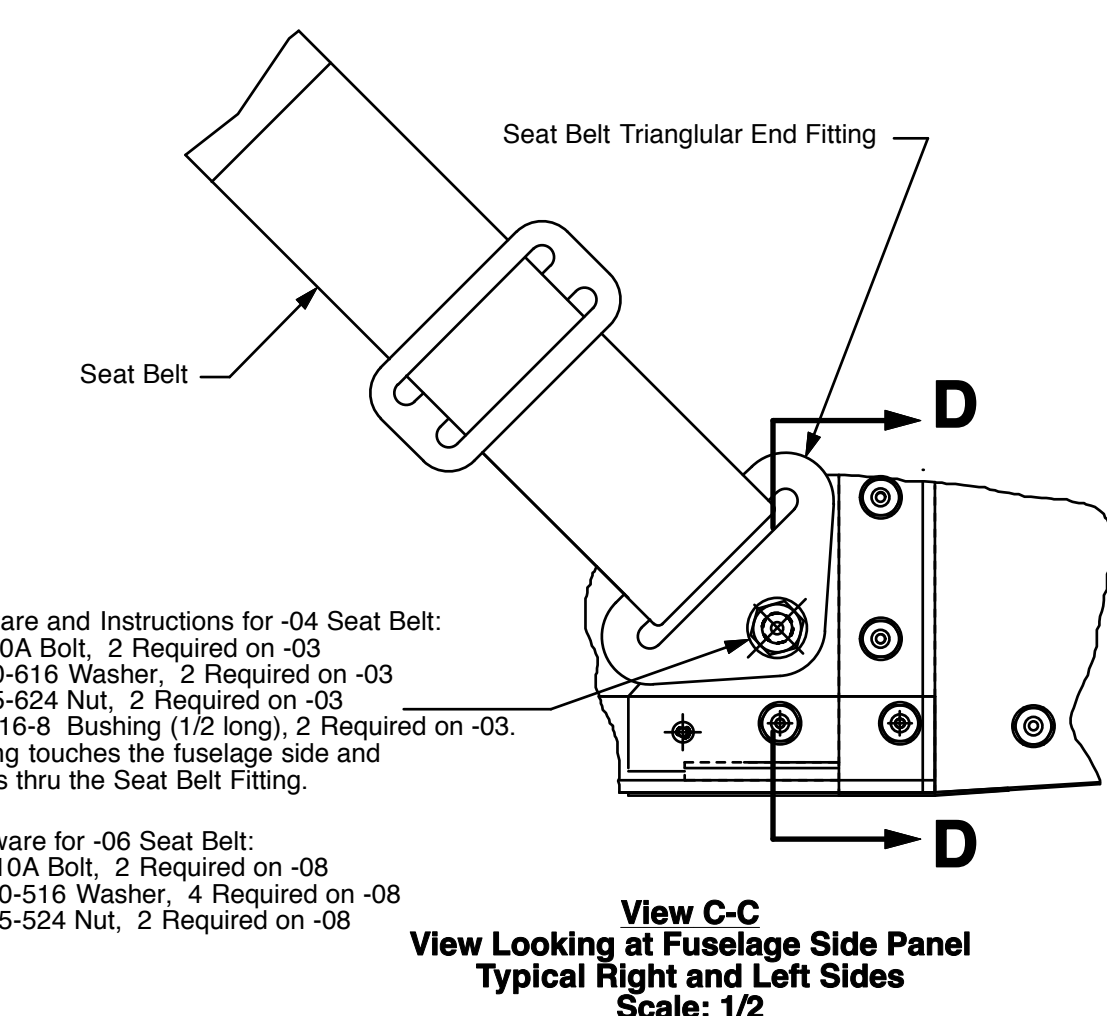
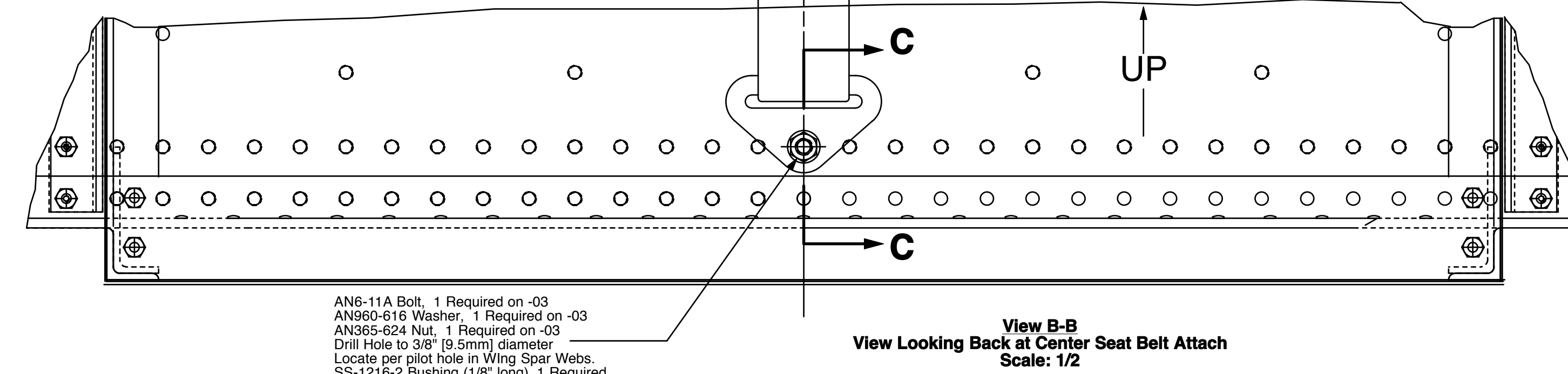
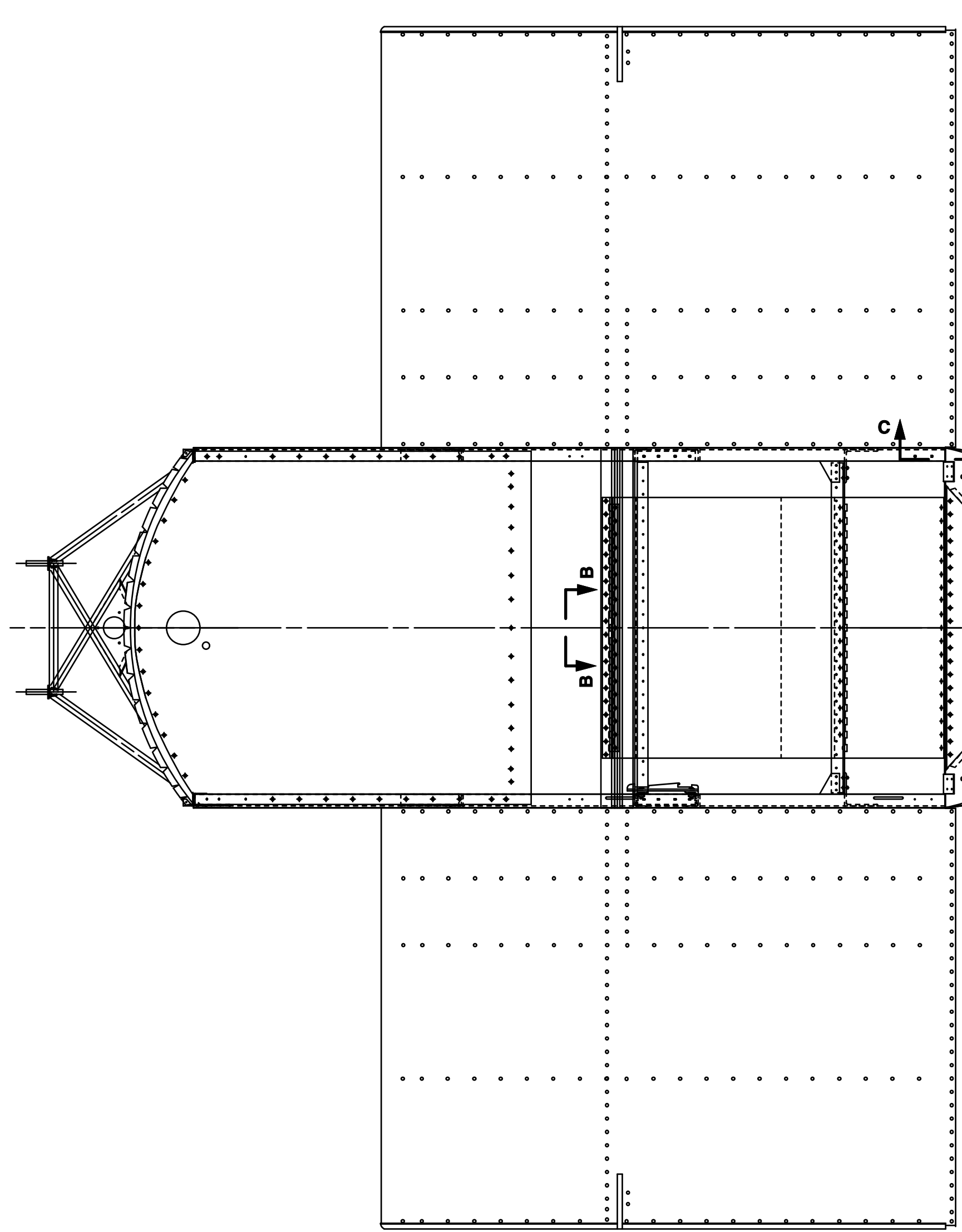
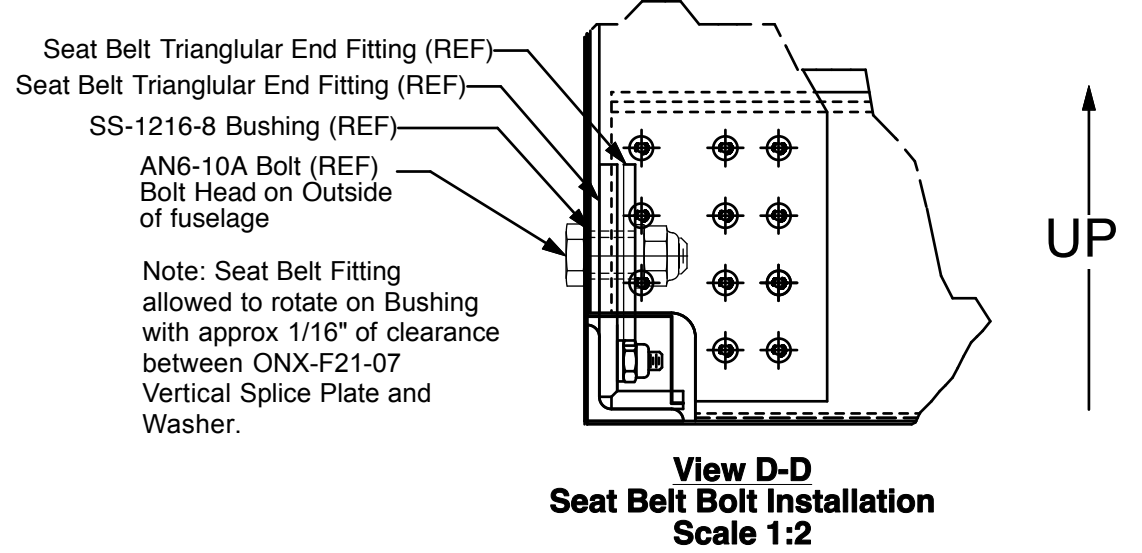
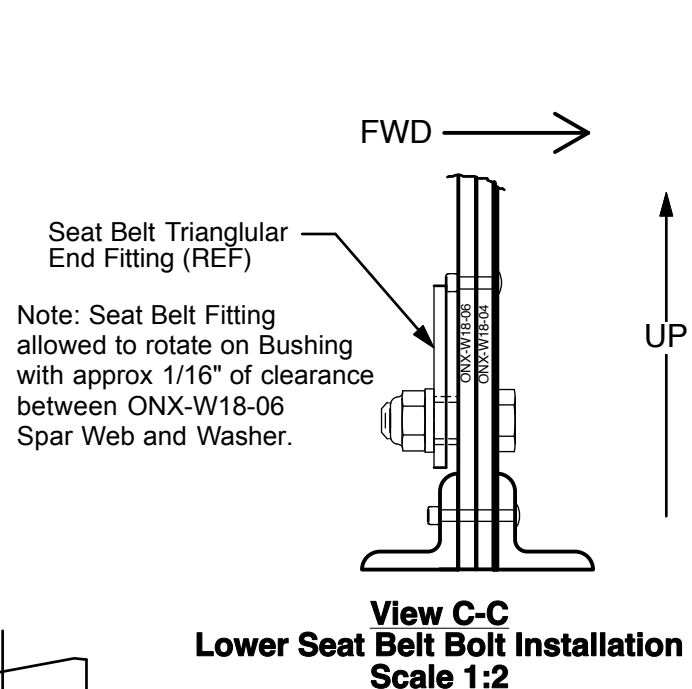
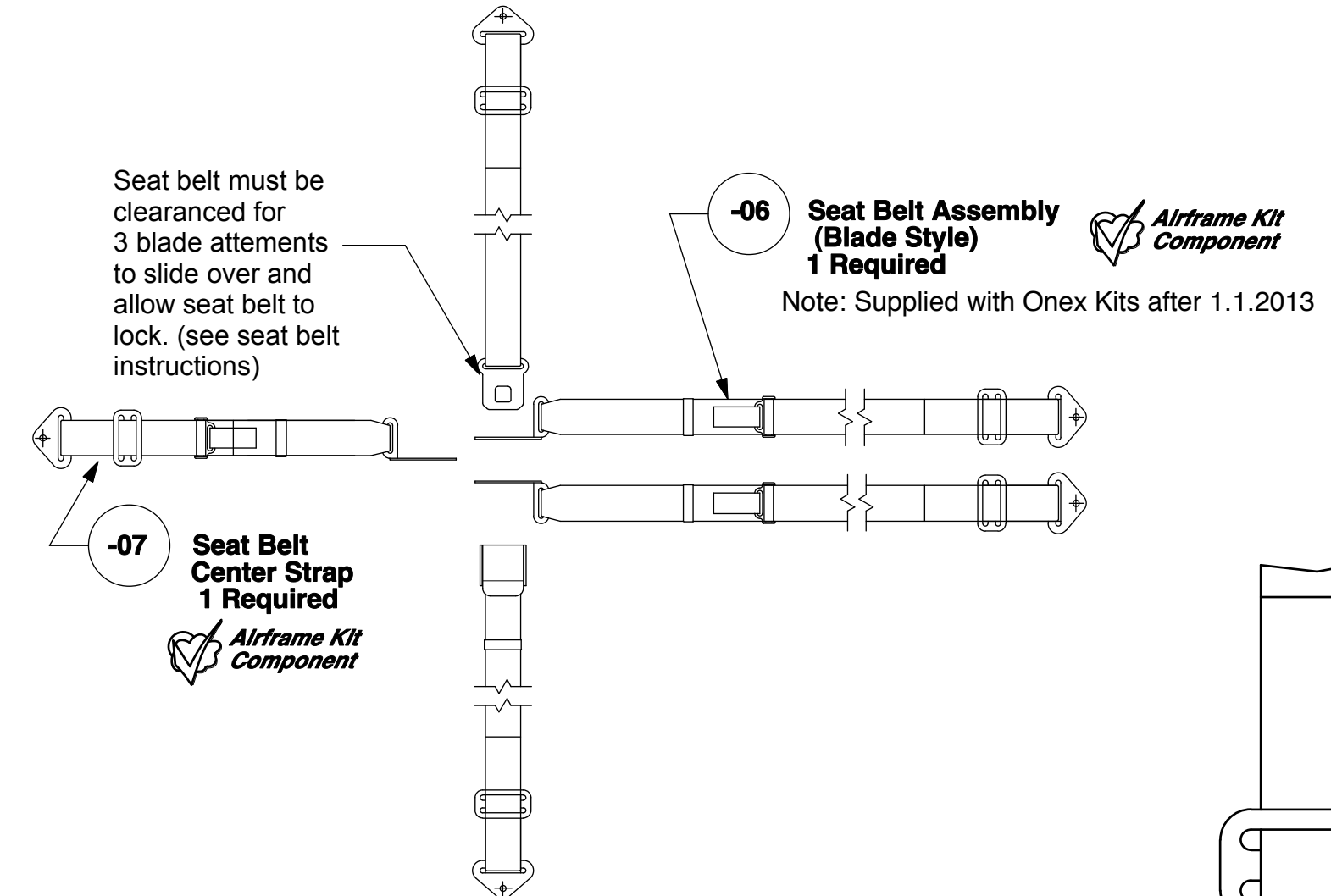
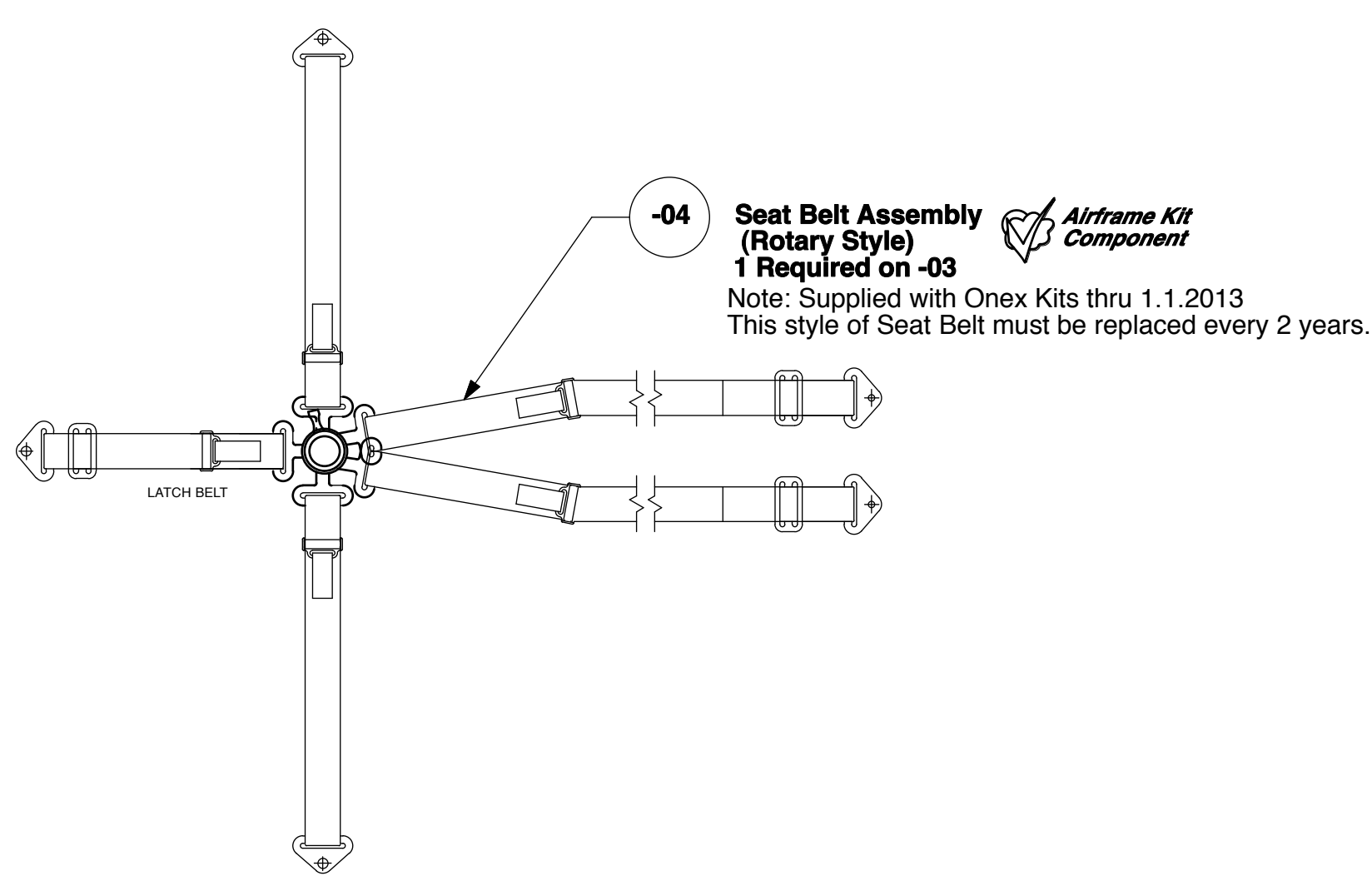

Dash Number	Engine Type / Size	Landing Gear Configuration
-01	AeroVee	Standard Gear
-02	AeroVee	Tricycle Gear

Configuration Dash Number
* Note: Only one Fuselage Box Structure Required, Refer to table above for desired Dash Number
** Note: Only one Seat Belt Installation Required depending on which seat belt was supplied with the kit.

Dash / Part Number	Qty Req'd	Part Title	Next Assembly
-08	1**	Seat Belt Installation (Blade Style)	ONX-F01
-03	1**	Seat Belt Installation (Rotary Style)	ONX-F01
-02	1*	Tricycle Gear Landing Gear Instl	ONX-F01
-01	1*	Std Gear Landing Gear Instl	ONX-F01

onex
Landing Gear and Seat Belt Installation

Drawing Scale 1/8 & Noted	Drawing Number ONX-F03	Revision B
------------------------------	---------------------------	---------------

