

The information disclosed herein is the property of the originator who reserves all patent, design, proprietary, manufacturing, use and sales rights thereto, except for the rights expressly granted to others. This document shall not be reproduced nor shall the information contained within be used by or disclosed to others except as expressly authorized by the originator. ©

Revision Letter	Change Description	09/17/04
A	Producibility Change -01R / -01L Upper Motor Mount Ø 1/8" [Ø 3.2mm] Pilot Holes - 2 Places (was) 13 Places Note: Pilot holes in XNS-F13-01 Fuselage Side Skin -02R / -02L Lower Motor Mount Ø 1/8" [Ø 3.2mm] Pilot Holes - 7 Places (was) 15 Places Note: Pilot holes in XNS-F13-01 Fuselage Side Skin -04R / -04L Angle Removed Ø 1/8" [Ø 3.2mm] Pilot Holes - 2 Places Note: Pilot holes in XNS-F13-01 Fuselage Side Skin -05 Angle Removed Ø 3/32" [Ø 2.6mm] Pilot Holes - 5 Places Note: Pilot holes in XNS-F13-01 Fuselage Side Skin	

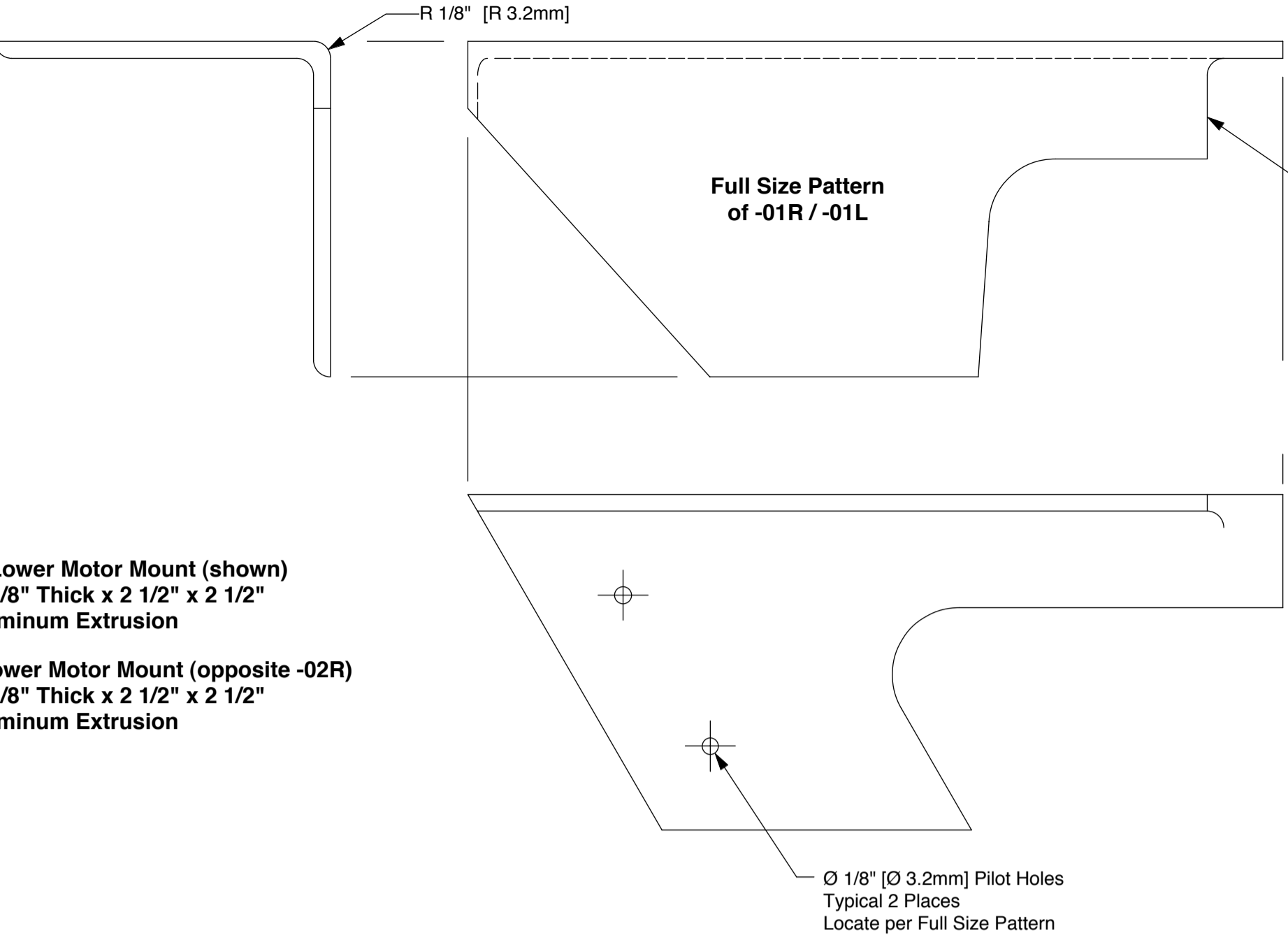
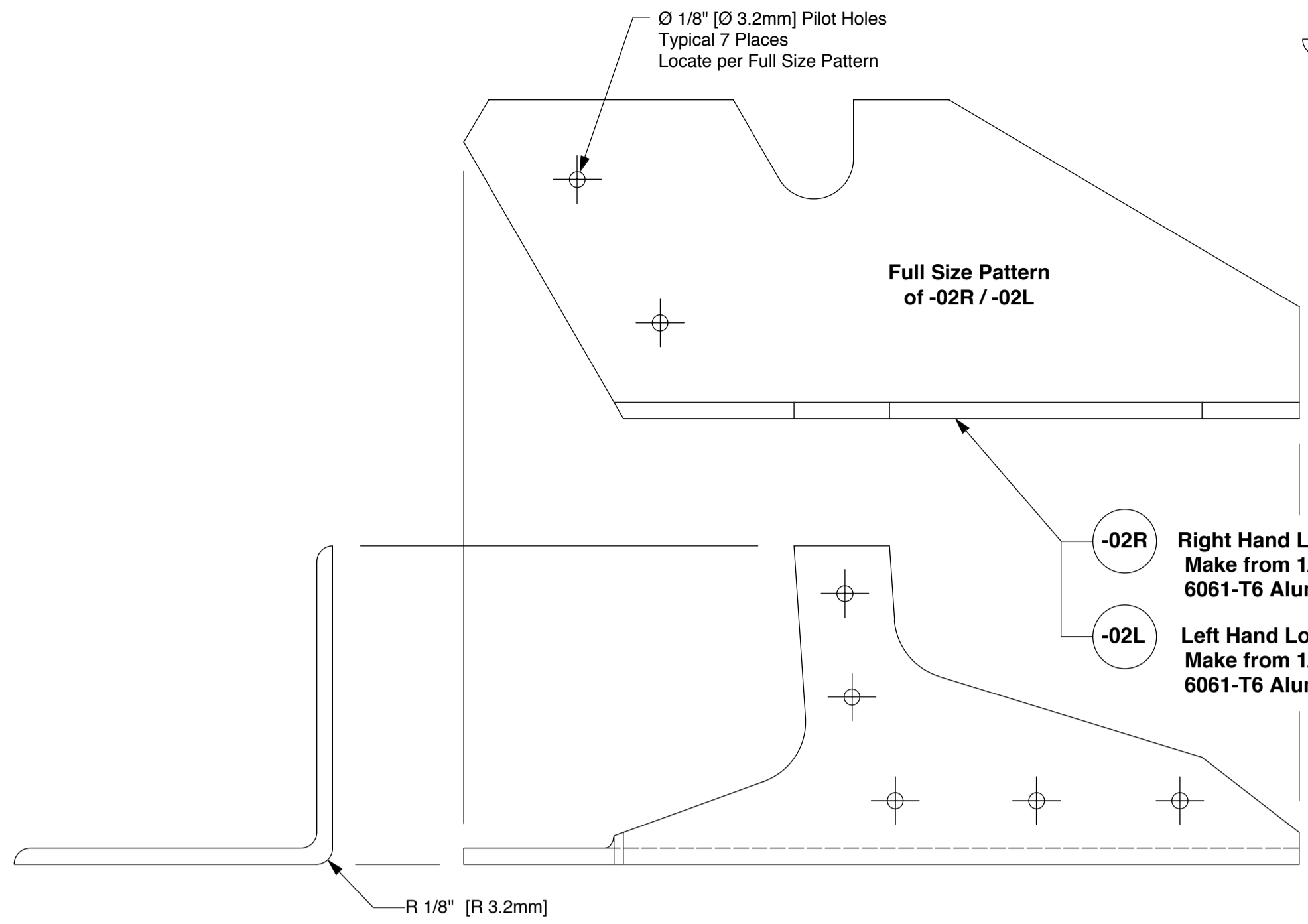

**-01R** Right Hand Upper Motor Mount (shown)  
 Make from 1/8" Thick x 2 1/2" x 2 1/2"  
 6061-T6 Aluminum Extrusion

**-01L** Left Hand Upper Motor Mount (opposite -01R)  
 Make from 1/8" Thick x 2 1/2" x 2 1/2"  
 6061-T6 Aluminum Extrusion

**-02R** Right Hand Lower Motor Mount (shown)  
 Make from 1/8" Thick x 2 1/2" x 2 1/2"  
 6061-T6 Aluminum Extrusion

**-02L** Left Hand Lower Motor Mount (opposite -02R)  
 Make from 1/8" Thick x 2 1/2" x 2 1/2"  
 6061-T6 Aluminum Extrusion

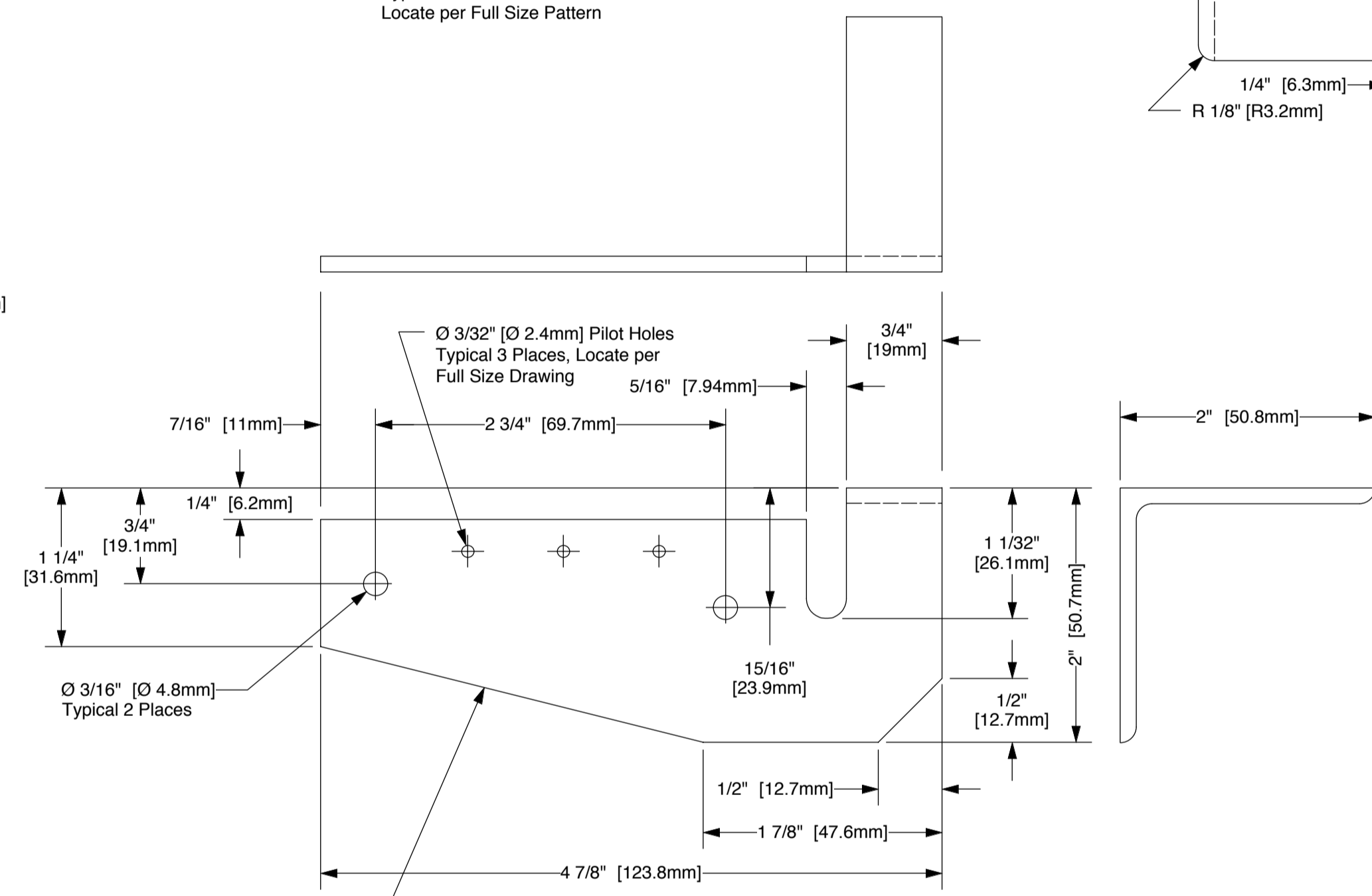
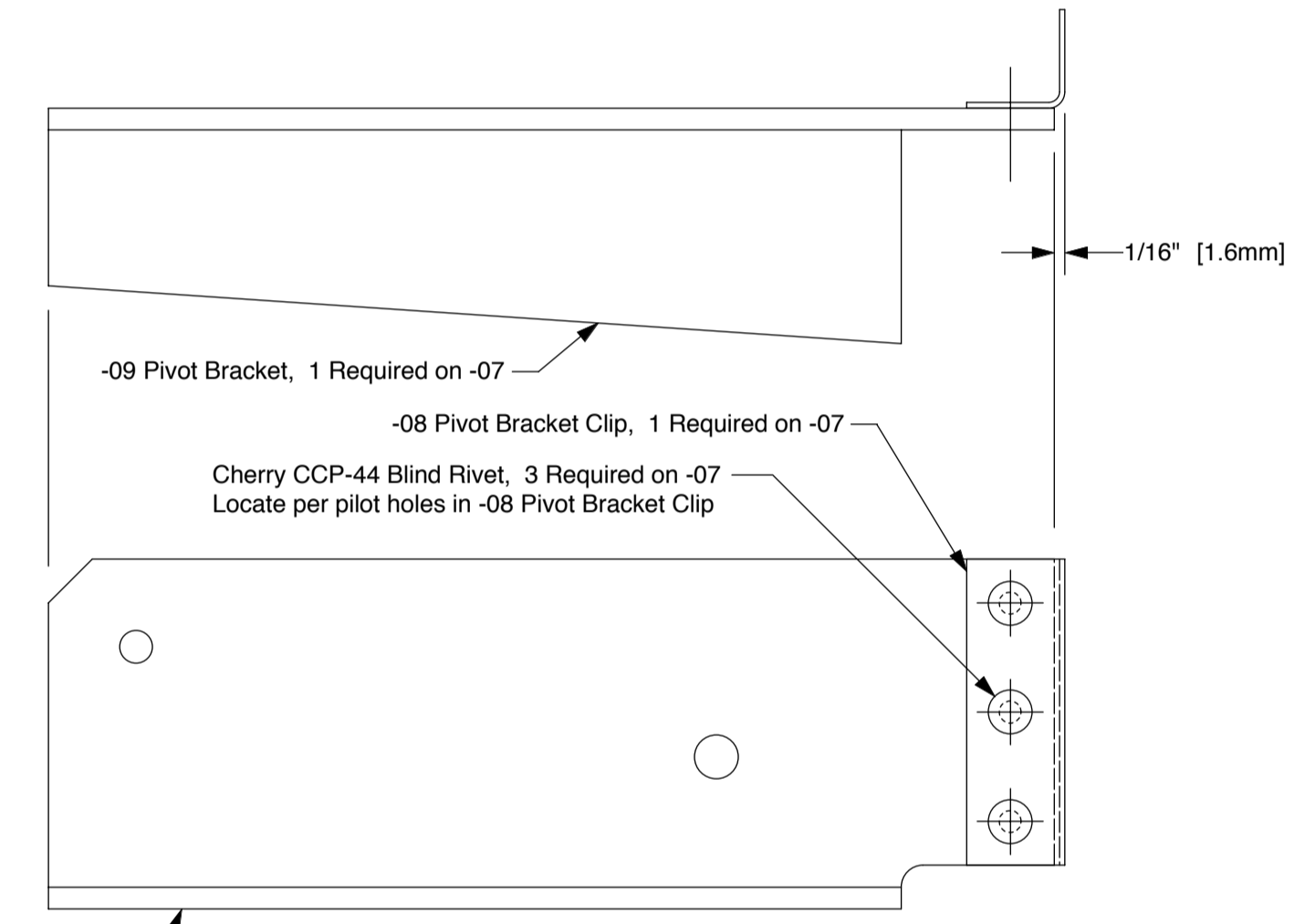
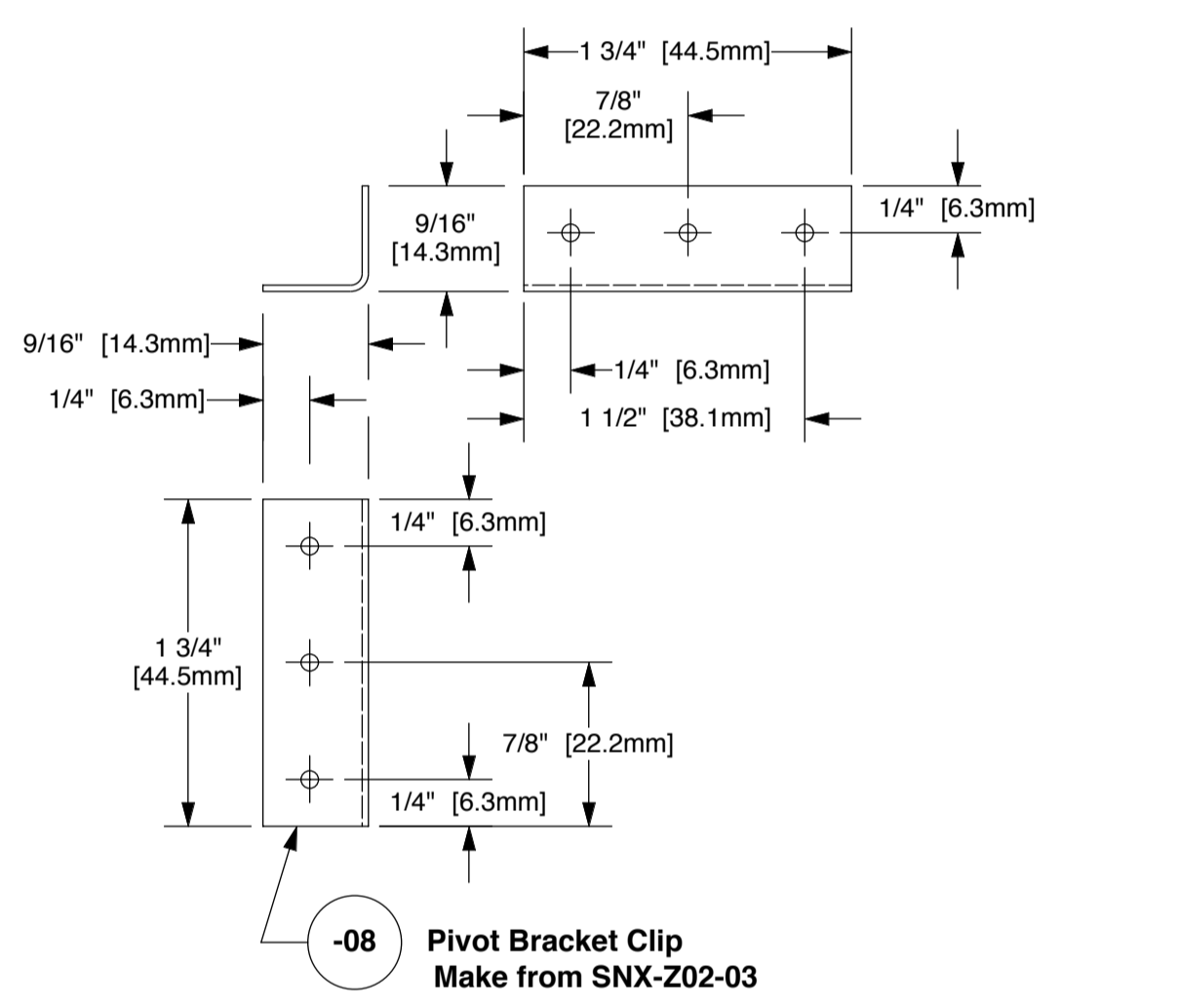
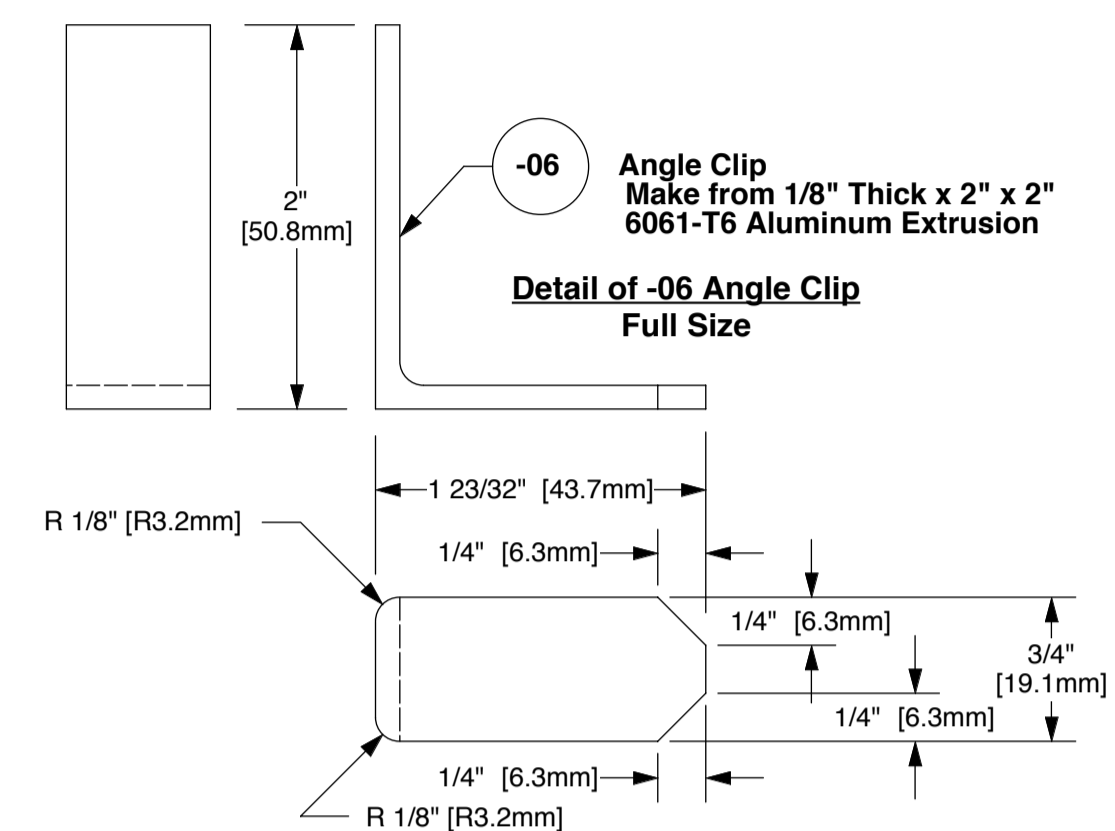

**-04R** Right Hand Rudder Pedal Mount Angle (shown)  
 1 Required on -03R  
 Make from 1/8" Thick x 2" x 2"  
 6061-T6 Aluminum Extrusion

**-04L** Left Hand Rudder Pedal Mount Angle (opposite -04R)  
 1 Required on -03L  
 Make from 1/8" Thick x 2" x 2"  
 6061-T6 Aluminum Extrusion

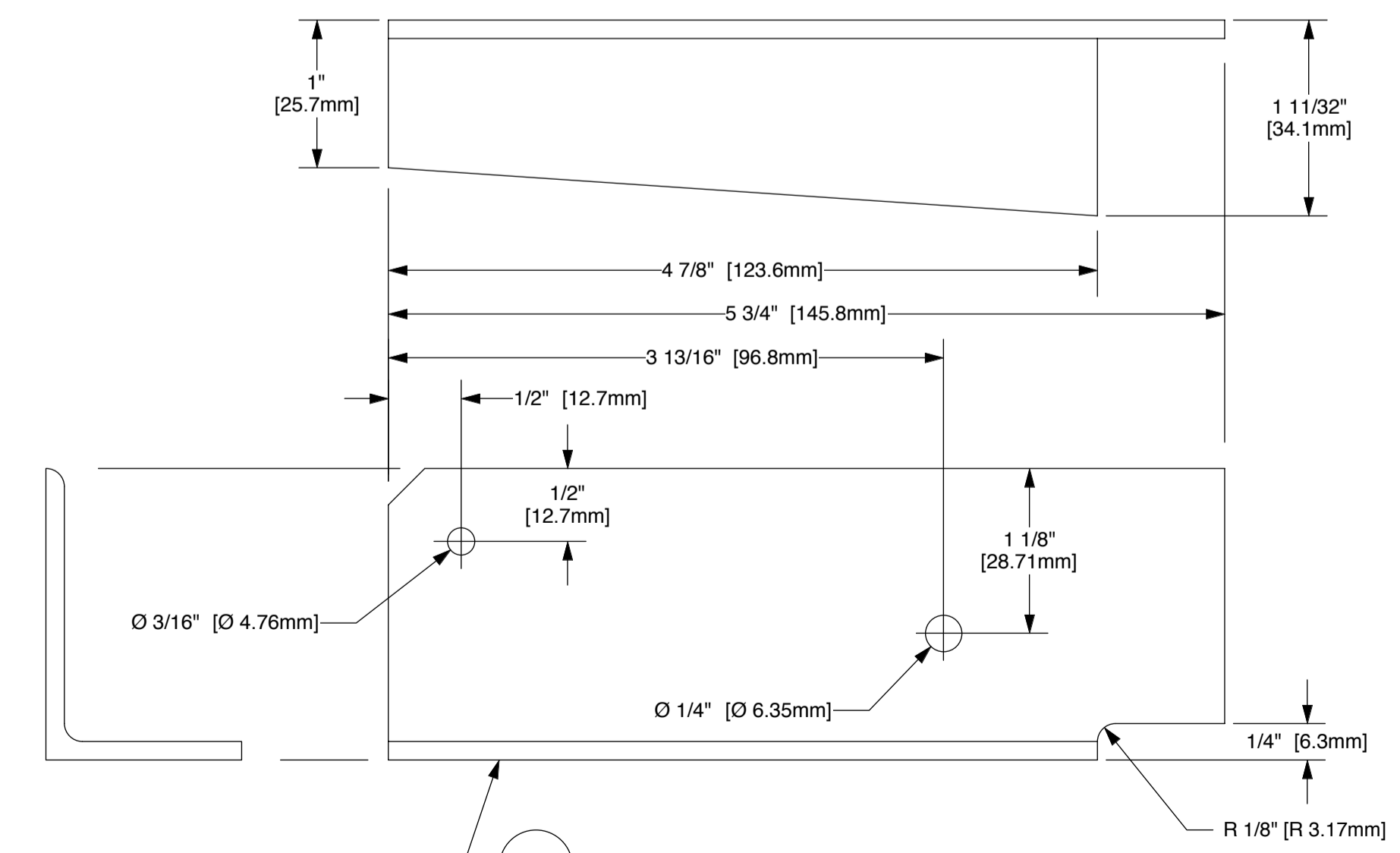
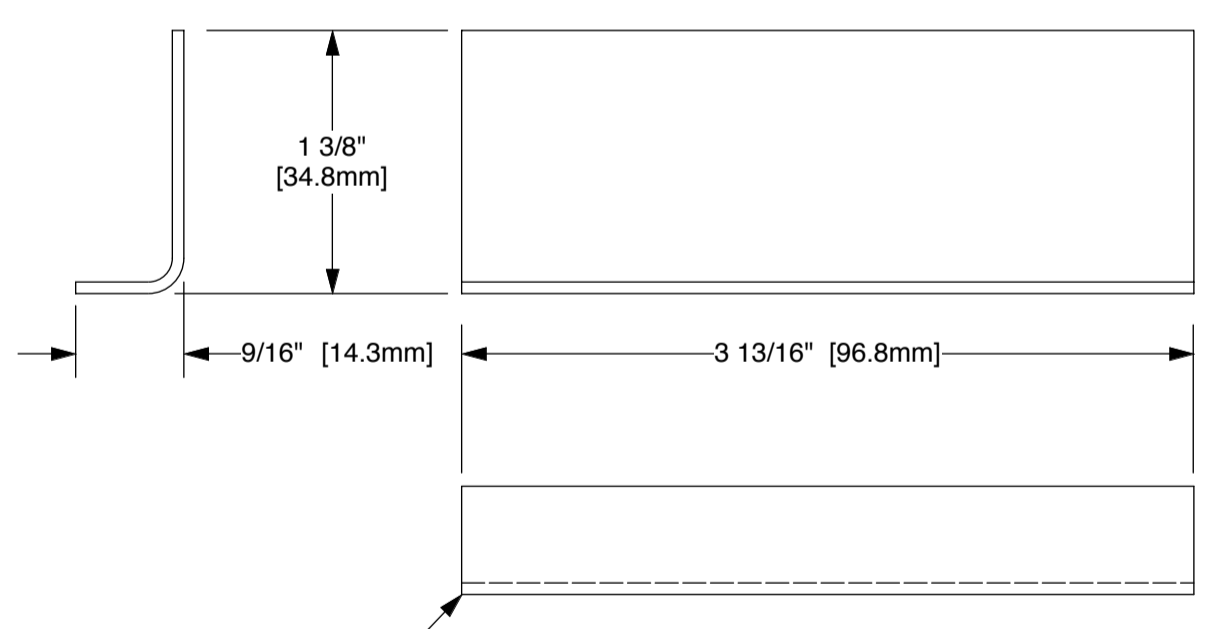

**-07** Spoiler Handle Pivot Bracket  
 Make from 1/8" Thick x 2" x 2" 6061-T6 Aluminum Extrusion

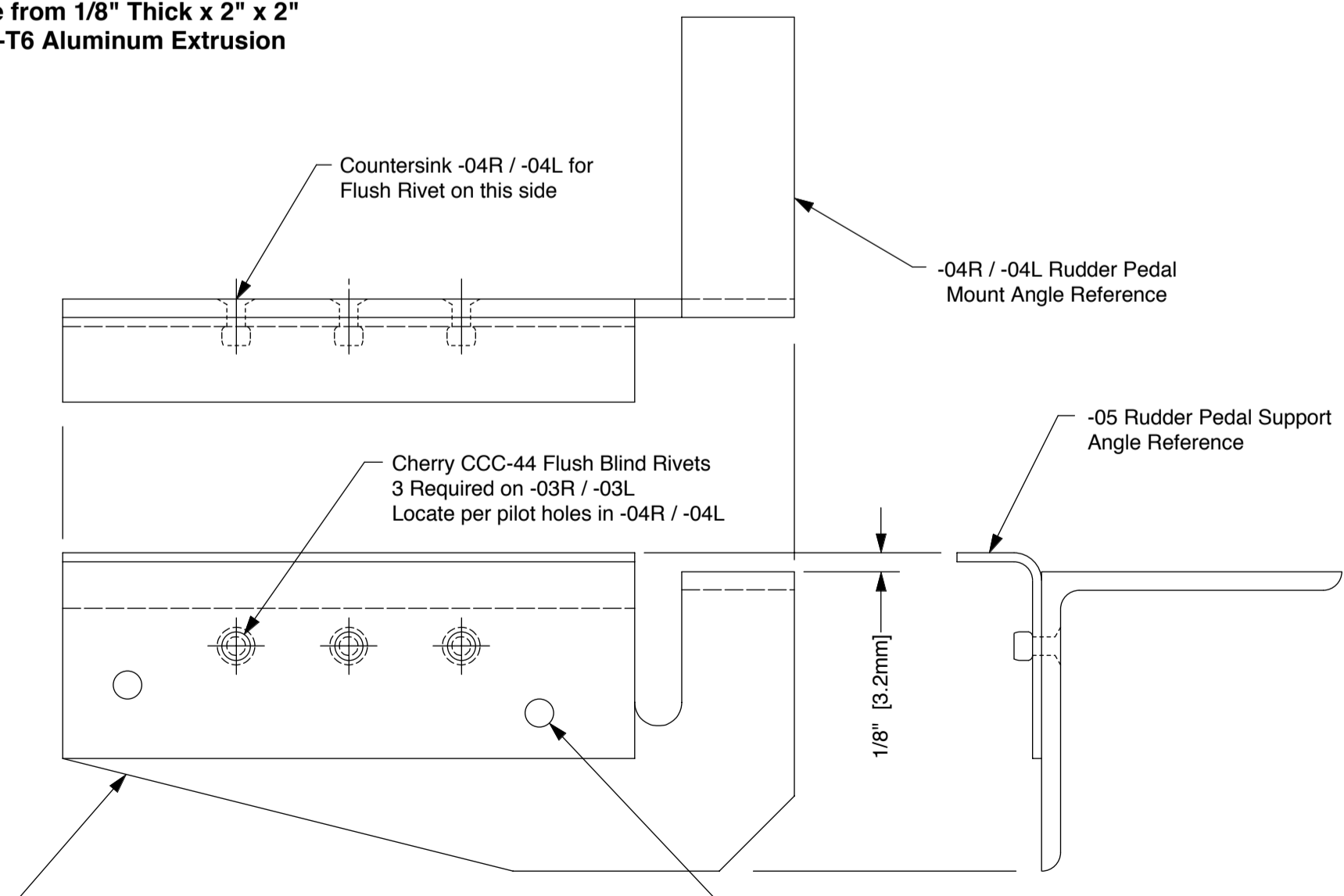

**-03R** Right Hand Rudder Pedal Mount Assembly (shown)

**-03L** Left Hand Rudder Pedal Mount Assembly (opposite -03R)

SNX-F15-11 Seat Belt Attach Gusset Plate  
 .090" Thick 6061-T6 Aluminum

Airframe Kit Component

-07	1	Spoiler Handle Pivot Bracket Assy	XNS-F11
-06	2	Angle Clip	XNS-F12
-03L	1	Left Hand Rudder Pedal Mount	XNS-F12
-03R	1	Right Hand Rudder Pedal Mount	XNS-F12
-02L	1	Left Hand Lower Motor Mount	XNS-F12
-02R	1	Right Hand Lower Motor Mount	XNS-F12
-01L	1	Left Hand Upper Motor Mount	XNS-F12
-01R	1	Right Hand Upper Motor Mount	XNS-F12
Dash / Part Number	Qty Req'd	Part Title	Next Assembly

## Xenos Fuselage Forward Side Panel Mounts & Misc. Details

Drawing Scale	Drawing Number	Revision
Full	XNS-F15	A